

ARMY AVIATION

NETWORK | RECOGNITION | VOICE | SUPPORT

August/September 2023



RAIDER X.[®]
CONNECTS THE FORCE
FOR TRUE OVERMATCH.

SIKORSKY 
A LOCKHEED MARTIN COMPANY



rolls-royce.com



BELL V-280 VALOR

Superior speed and range for Army modernization

Optimum capability requires propulsion excellence. The Rolls-Royce propulsion solution for the Bell V-280 Valor features a proven, low-risk AE 1107F engine and a fully integrated system design. Backed by an experienced American workforce in a modernized, advanced manufacturing facility, the Rolls-Royce propulsion system is **ready now** for the U.S. Army.



10



14



18



20



30

Contents

August/September 2023, Vol. 72, No. 8 & 9

TO THE FIELD

- 10 Army Aviation Branch Chief's Corner**
By MG Michael C. McCurry II
- 14 Director of Army Aviation Update**
By MG Wally Rugen
- 18 Chief Warrant Officer of the Branch Update**
By CW5 Michael Corsaro / CW5 Keoni Navedo
- 20 Branch Command Sergeant Major Update**
By CSM Kirk Coley / SGM Ruben Davila
- 24 Combat Readiness Center Update**
By LTC Sean O'Connell
- 26 Reserve Component Aviation Update**
By LTC Aaron Schilleci
- 28 128th Aviation Brigade Update**
By SSG Charles Hayworth and SSG Audley H Rumble
- 30 CCDC AVMC Tech Talk**
By Ms. Tia Larsen-Calcano and Mr. Huy "Ken" Hoang
- 32 Ask the Flight Surgeon**
By MAJ (Dr.) Devon Greer

FROM THE FIELD

- 34 European North Atlantic Treaty Organization Helicopter Pilot Training Program**
By Mr. Sam Baker
- 38 Readily Available Information Technology Tools Improve Retention and Readiness**
By MG (Ret.) Tim Gowen, and COL (Ret.) Rich Ferguson
- 42 The Army's AH-64 New Equipment Training Team (NETT)**
By Mr. Ricky Denny and Mr. Tom Beck
- 46 2023 AAAA Functional Award Winners**



124



128



129



134



136

Contents

August/September 2023, Vol. 72, No. 8 & 9

SPECIAL FOCUS — 2023 Blue Book

48 2023 Blue Book Directory - ARMY AVIATION Magazine's original directory of updated contact information for government and military units, offices, and organizations related to the Army Aviation community.

SPECIAL FOCUS — 2023 Scholarship Recipients

110 2023 Scholarship Awards

DEPARTMENTS

AAAA NEWS

AAAA President's Cockpit.....	8
AAAA VP Chapter Affairs.....	128
Chapter News.....	129
AAAA VP Membership.....	132
New Members.....	133
AAAA Family Forum.....	134
AAAA Legislative Report.....	140
AAAA Scholarship Foundation Donors.....	127

ARMY AVIATION COMMUNITY NEWS

Advertisers Index.....	139
Advertiser Spotlight.....	138
Art's Attic.....	141
Briefings.....	6
Enlisted Spotlight.....	22
Hall of Fame.....	142
Historical Perspective.....	126
Industry News.....	139
In Memoriam.....	131
People on the Move.....	136
Recently Departed.....	135
Vietnam Helicopter Pilots Association Feature.....	124

ARMY AVIATION is the official journal of the Army Aviation Association of America (AAAA). The views expressed in this publication are those of the individual authors, not the Department of Defense or its elements. The content does not necessarily reflect the official U.S. Army position nor the position of the AAAA or the staff of Army Aviation Publications, Inc., (AAPI). Title Reg® in U.S. Patent office. Registration Number 1,533,053. SUBSCRIPTION DATA: ARMY AVIATION (ISSN 0004-248X) is published monthly, except May and September by AAPI, 593 Main Street, Monroe, CT 06468-2806. Tel: (203) 268-2450, FAX: (203) 268-5870, E-Mail: aaaa@quad-a.org, Army Aviation Magazine E-Mail: magazine@quad-a.org, Website: <http://www.quad-a.org>. Subscription rates for non-AAAA members: \$35, one year; \$65, two years; add \$10 per year for foreign addresses other than military APOs. Single copy price: \$4.00. ADVERTISING: Display and classified advertising rates are listed in SRDS Business Publications, Classification 90. POSTMASTER: Periodicals postage paid at Monroe, CT and other offices. Send address changes to AAPI, 593 Main Street, Monroe, CT 06468-2806.

AEROSONDE[®]

MK 4.8 HQ UAS



PURPOSE-BUILT FOR FTUAS



LEARN MORE



TEXTRON Systems

TextronSystems.com



© 2023 Textron Systems Corporation.

Founders / Art and Dotty Kesten

Publisher / William R. Harris Jr.

Editor / CW4 (Ret.) Joseph L. Pisano Sr.
editor@quad-a.org

Associate Editor / CW5 Adam Jarvis
adam@quad-a.org

Director of Design & Production
Anne H. Ewing
magazine@quad-a.org

Contributing Editor / Mark Albertson
mark@quad-a.org

Family Forum Editor / Judy Konitzer
judy@quad-a.org

Director of Advertising & Exhibit Sales
Robert C. Lachowski
bob@quad-a.org

Deputy Director of Advertising & Exhibit Sales
Erika Burgess
erika@quad-a.org

Advertising & Exhibit Sales Manager
Carmen Tuohy
carmen@quad-a.org

Marketing Director / Jennifer Chittem
jenn@quad-a.org

Social Media Manager / Chelsea Jarvis
chelsea@quad-a.org

Director Data Services / Ben Marini
ben@quad-a.org

Circulation Department
Mira Auxier
Deb Cavallaro
Debbie Coley
Jackie Harris

Editorial Address

593 Main Street, Monroe, CT 06468-2806
Tel: (203) 268-2450 / Fax: (203) 268-5870

*Visit our website for additional
articles and updates.*

ARMYAVIATIONmagazine.com

On The Cover

PAID ADVERTISEMENT:
Purposely built as a complete, integrated weapon system, RAIDER X delivers overmatch with near peer threats on the modern battlefield. With transformational speed, lethality and survivability, RAIDER X provides real-time, mission-critical capabilities at the front of the fight. Caption provided by the advertiser.

Briefings

GEN James Lindsay Dies



U.S. ARMY PHOTO

GEN (Ret.) James J. Lindsay, the first commander of U.S. Special Operations Command, died Aug. 5, 2023 in Vass, North Carolina. He was 90. Over more than 38 years, he commanded in both peacetime and in Vietnam, and the 82nd Airborne Division, the United States Army Infantry School, the XVIII Airborne Corps, the United States Readiness Command, and was the first Commander in Chief, United States Special Operations Command. Retiring July 1, 1990, he founded the Airborne and Special Operations Museum Foundation in 1990 and served as a senior mentor for the Army's Battle Command Training Program (BCTP) from 1990 to 2009.

Army Aviation Supporting Maui Wildfire Efforts

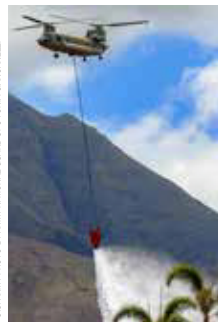

U.S. ARMY PHOTO BY ARMY NATIONAL GUARD SPC DONIA DANCANELLI

An Army CH-47 Chinook drops seawater over the perimeter of dry land that surrounds the areas impacted by the wildfires in Lahaina, Maui, Aug. 16, 2023. Members of the Hawaii Army and Air National Guard

as well as Army active duty and Reserves are supporting Maui County authorities to provide immediate security and safety to those affected by the wildfires. The fires decimated the historic town of Lahaina and, as of this writing, the death toll stands at more than 115 with 388 reported still missing, making it the deadliest wildfire in the U.S. in 100 years. BG Stephen Logan, Assistant Adjutant General of Hawaii and a Master Army Aviator, has been designated to synchronize the military response.

Huebscher Awarded Soldier's Medal



U.S. ARMY PHOTO BY KELLY MORRIS

CW5 Nigel P. Huebscher, command chief warrant officer for 1st Aviation Brigade, Fort Novosel, AL, received the Soldier's Medal on Aug. 7, 2023 for saving two people from a burning home in Bonifay, FL on Oct. 9. As he and his family were returning from a trip, Huebscher saw a home burning. He ran towards the home, jumping a

locked gate to gain entrance, as his wife Devi called 911. In a matter of seconds, he helped two elderly people escape the burning home before it was totally consumed by the fire.

Fort A.P. Hill Renamed

On Friday, Aug. 25, 2023, the Army renamed Fort A.P. Hill, Virginia, a training post near the nation's capital, as Fort Walker to honor the service's first female surgeon and Medal of Honor recipient from the Civil War, Dr. Mary Edwards Walker. The first woman to earn a medical degree in America and the only woman to receive the Medal of Honor, Walker was a contract surgeon for the Army during the Civil War, often crossing enemy lines to treat sick civilians. It is the eighth of nine Army posts being renamed to shed Confederate names from U.S. military installations.



LIBRARY OF CONGRESS PHOTO

Army Aviation at Oshkosh



EOA AVIATION SCENEOPIQUE

U.S. Army Chief Warrant Officer of the Aviation Branch, CW5 Mike Corsaro (center) and CW5 Michael Maine, USAACE Chief of Warrant Officer Aviation Proponency, are interviewed on July 29 as part of the Experimental Aircraft Association's 70th AirVenture. All services provided aircraft to the annual fly-in convention which was held July 24-30 at Wittman Regional Airport in Oshkosh, WI. See the interview and other videos at www.eaa.org/airventure/live.

DOD Approves PCS Pet Travel Expenses

The Department of Defense has approved a new policy to cover pet travel expenses, like pet shipping or quarantine fees, incurred by Service members during a permanent change of station. Effective January 1, 2024, military Service members going through a PCS within the continental United States can be reimbursed up to \$550 for one household pet, either cat or dog, and up to \$2,000 for moves to or from a location outside the continental United States to cover costs related to the transportation of a pet.



Experienced.
Flexible.
Mission Focused.

AKIMA

AKIMA
LOGISTICS SERVICES

AKIMA
TECHNICAL SOLUTIONS

PINNACLE
SOLUTIONS
AN AKIMA COMPANY



Moving Forward

It is hard to believe that five months have elapsed since our Annual Summit in Nashville.

As reported previously, your National Executive Group (NEG) met at the Connecticut Headquarters to synchronize our path ahead back in June. Part of our discussions centered around the identification and selection of our new Standing Committee Chairs; I am grateful to those that have agreed to take on the Chairman duties and responsibilities and am pleased to announce the following appointments: By-Laws and Legal – COL (Ret.) Shelly Yarborough; Civilian Affairs – BG (Ret.) Kelly Thomas; Finance – BG (Ret.) Tim Edens; Hall of Fame Trustees – CSM (Ret.) Tod Glidewell; Industry Affairs – MG (Ret.) Frank Muth; Legislative Affairs – LTC (Ret.) Josh Baker; National Guard and Reserve – BG (Ret.) J. Ray Davis; Awards Selection – COL (Ret.) Scott Schisser; and Strategic Planning and Communications – COL (Ret.) Angelia Farnell.

Speaking of assignments, I have to say this should be one of our favorite issues of ARMY AVIATION Magazine, the Annual “Blue Book” that lists all of the major Army Aviation offices, organizations and formations. Between the invaluable detailed point of contact information and the photos of all our senior Aviation leaders, it really provides an opportunity to appreciate the breadth, depth, and contributions of Army Aviation to the greater Army and Joint Force.

In August, several of us in the AAAA National Executive Group had the privilege to attend the retirement and Change of Responsibility ceremonies of our Senior Army Aviator and (now former) Army Chief of Staff, GEN Jim McConville. What an unparalleled example of professionalism, leadership, and selfless service GEN McConville has provided all of us in a career spanning over 42 years. We look forward to his continuing contributions to the Army and Army Aviation in retirement.

We have now entered the rewarding AAAA event season with the September Aircraft Survivability Equipment Symposium in Huntsville already behind us by the time you read this (notably, ASE registration is running significantly above last year’s event in Lexington, KY). In addition, we have our Senior Executive Associates meeting with the Army Aviation Six Pack, Plus One, led by GEN (Ret.) J.D. Thurman, following the AUSA Annual Meeting in Washington, D.C. on October 12th. On the heels of that, we have the Cribbins Readiness Forum in Huntsville, AL November 13-15 and then we end this calendar year with the Luther Jones Army Aviation Depot Forum in Corpus Christi, TX on December 5-6.

And among all of the above we have been inducting numerous individuals into the Gold Order of St. Michael around the country to recognize those who have given so much to our Branch and Army (see pages 130-131 for photos and



U.S. ARMY PHOTO BY SGT DEONTE ROWELL

GEN James C. McConville (second from right), flanked by his family to his right and GEN Mark Mille, Chairman of the Joint Chiefs of Staff, is honored during a retirement ceremony at Joint Base Myer-Henderson Hall in Arlington, Virginia, Aug. 3, 2023.

details). Also, it’s important to highlight that our Executive Director, Mr. Bill Harris, and Senior Vice President, MG (Ret.) Wally Golden, visited the Vietnam Helicopter Pilots Association Annual Reunion in San Antonio, TX on July 1 where they met with the VHPA Executive Committee regarding an even closer relationship with the VHPA in future years to include reprinting articles from their magazine (see page 124 in this issue). The VHPA is one of the largest AAAA Scholarship Foundation contributors with historical funding of well over \$400,000!

In the next Army Aviation Magazine issue, we will provide an update on our planning and preparation for the 2024 Summit in Denver, Colorado. Spoiler alert, we are going to be in numerous hotels and Industry exhibit demand is off the charts. Who knew the AAAA Summit would grow as much as it has after we signed the 2024 contract for the Denver Gaylord back in 2019!

To all our members, thanks for all you are continuing to do for our Army, Army Aviation, and our Association. We hope you and your families have had a wonderful summer, and as always, I look forward to hearing from you!!

Above the Best.

*MG Walt Davis, U.S. Army Retired
36th President, AAAA
walt.davis@quad-a.org*

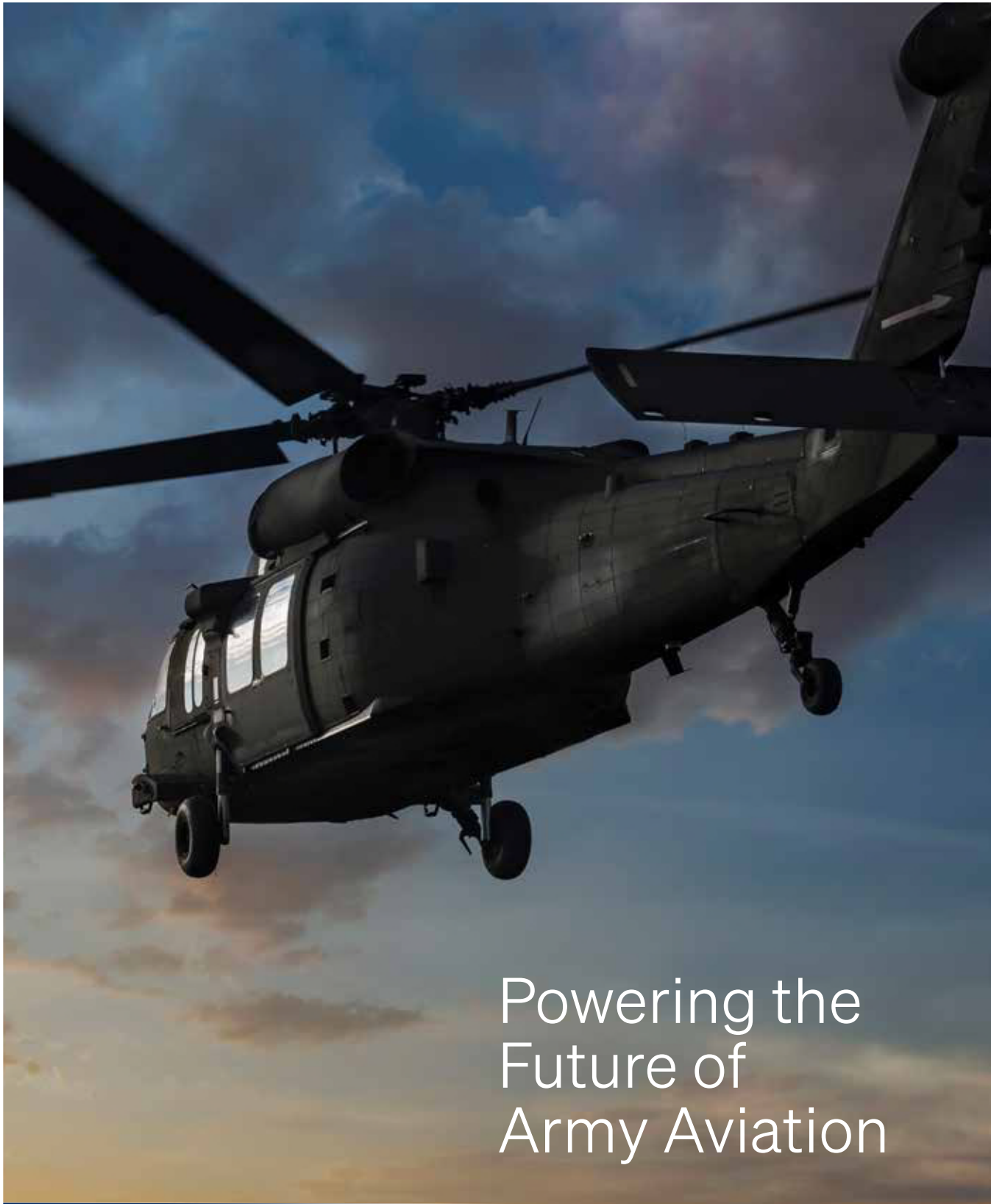

Powering the Future of Army Aviation



GE Aerospace



Learn more
geaerospace.com/T901



Are We There Yet? An Update on Transitioning to the Future

By MG Michael C. McCurry II



U.S. ARMY PHOTO BY CPT GABRIELLE HILDEBRAND

In last year's AAAA Blue Book edition, I discussed Army Aviation's path to the future in my article, *Transitioning to the Future* (August/September 2022).

Much has happened in Aviation since then! For example, the Army released its new doctrine manual, FM 3-0, Operations, in October 2022; the Army down-selected V-280 as the Future Long Range Assault Aircraft (FLRAA); Army Aviation celebrated its 40th anniversary as a branch in April 2023, which included the redesignation of Fort Rucker to Fort Novosel and renaming the USAACE Headquarters to McNair Hall. The post redesignation and headquarters renaming honored two extraordinary Aviation Soldiers whose contribution to Army Aviation and to our nation are unquestionable – MG (Ret.) Carl McNair, Jr., and CW4 (Ret.) Michael Novosel.

When my kids were younger, and we took road trips, I can remember the question that invariably emanated from the backseat, "Are we there yet?" It made no difference whether we were just a few minutes out of the driveway or a few miles from the destination the question came – and frequently. Regardless

U.S. Army AH-64 Apache helicopters assigned to the 1st Battalion, 3rd Aviation Regiment (Attack Battalion), 12th Combat Aviation Brigade fired 15 Air-to-Ground Missile (AGM) 114R Hellfire II's at Karavia Range Complex, Greece, on May 12, 2023. Five AH-64D and AH-64A Apache helicopters from the Hellenic Armed Forces participated in the live fire exercise, demonstrating the ability to mass precision fires as part of a multinational team.

of age, we all are naturally curious about the future because it is an unknown, and we anticipate and are anxious for it to occur. As such, I am updating you on some salient initiatives.

Where Are We Now?

Our Army Aviation modernization efforts for the Future Vertical Lift (FVL) ecosystems are on track. The down-select of the V-280 Valor as the FLRAA, the next-generation vertical lift tactical assault/utility aircraft, provides the combined arms team with dominant increases in speed, range, and mobility over the current H-60 aircraft fleet. As then-director of the FVL Cross-Functional Team, MG Walter Rugen, stated, "This down-select represents a strategic pivot for Army Aviation to the transformational speed and range our Army needs to dominate future battlefields."

Building off the "Try, Buy, Inform" demonstration for Future Tactical Uncrewed Aircraft Systems (FTUAS) that



TRAINING THAT DELIVERS.

FSI DEFENSE

A FLIGHTSAFETY INTERNATIONAL COMPANY

The success of every mission relies on preparation. FSI Defense puts the minds of former military to work for you—people who know what it takes to complete the objective.

**Partner with us for your training.
Visit [FSIdefense.com](https://www.fsidefense.com) to get started.**

was completed in May 2021, Army Aviation will continue down-select from multiple industry partners. We will begin fielding FTUAS in FY25 replacing all Shadow UAS in the BCTs as part of the Program of Record. The 12-month demonstration included 20 Soldier Touchpoints (new equipment training, field training exercises, and Combat Training Center (CTC) rotations) across five BCTs and included the training of 61 operators and 56 maintainers. The demonstration resulted in over 1500 flight hours across more than 500 separate flights.

Our Future Attack Reconnaissance Aircraft (FARA) and the broader ecosystem of Launched Effects and Long-Range Precision Munitions will maximize reach, stand-off, lethality, and survivability to dominate our adversaries in the upper tier of the ground domain. The program remains on course. We expect two prototypes to fly in FY24, and the Army will conduct the Small Prototype User Evaluation for Launch Effects in the 3rd quarter, FY24.

While we modernize for the future, optimized fleets will keep pace with the evolving threat and support Large Scale Combat Operations (LSCO). Army Aviation's modernization strategy optimizes resources for sustainment and targeted modernization of currently fielded systems with the development of FVL systems to ensure we provide the best capability to the Commanders and Soldiers we support.

However, Army Aviation is about more than equipment. It is also about developing our Aviation Soldiers and Leaders during institutional training. Our Professional Military Education (PME) and training initiatives have significantly progressed. First, our revision of Aviation doctrine and tactical publications to align with the new FM 3-0, Operations, is on schedule. Our FM 3-04, Army Aviation, is in worldwide staffing and scheduled for field release in December 2023. Second, we have changed Aviation PME to ensure our Aviation Soldiers and Leaders can operate in multiple domains. USAACE has revised the Officer, Warrant Officer, and Noncommissioned Officer (NCO) PMEs to focus on making better leaders to win in Large Scale Combat Operations (LSCO).

The Aviation Maintenance Training Program (AMTP) standardizes Aviation maintenance training across all Army components (COMPOs). The Enterprise-working group, Directorate of Training and Doctrine, and Directorate of Evaluation and Standardization will continue to assist units with AMTP implementation and issues. We are currently pursuing funding for an automation pilot program for AMTP.

The Unit Trainer/Evaluator (UT/E) provides commanders with a tool to support the Aircrew Training Program on certain tasks previously performed by instructor pilots (IPs); thus, allowing the IP to invest more time in tactically focused, collective-level training events. The Directorate of Evaluation and Standardization (DES) validates UT/Es in the operational force after selection by commanders. DES will continue to work across all components to validate UT/Es. The key is command involvement and careful selection of candidates.

USAACE continues the Aviation Tactics Instructor Course (ATIC) development. If conditions are set, we project transitioning from the legacy IP course to the ATIC model in FY25. ATIC anticipates 12 Reconfigurable Virtual Collective Trainers – Aviation (RVCT-A) will arrive at Fort Novosel as early as 3rd quarter, 2024 to support this innovative course. The RVCT-A is a critical requirement for the ATIC students to conduct collective training exercises and evaluations prior to graduation.

What Do We Need To Do?

To get to our destination, Aviation Soldiers must focus on sharpening their Aviation skills and knowledge. When I talk to the Captains in the Aviation Captain's Career Course (AvCCC), I emphasize the importance of improving technical and tactical proficiency. To do this, they must do those jobs that will enhance their skill levels, become masters of their craft, and provide aviation core competencies to the combined arms team as well as build relationships. For commissioned officers becoming a pilot-in-command (PIC), Air Mission Commander, and jobs such as platoon leader and company command, attending schools like Air Cavalry Leaders Course, and the Airborne, Air Assault, and Ranger courses are essential. Our warrant officers should also sharpen their skills by achieving PIC status, and performing UT/E, IP, MTP, Safety Officer, and Aviation Mission Survivability Officer jobs. Our NCOs should seek assignments such as crew chief, mechanic, operations specialist, team chief, technical inspector, and maintenance supervisor to sharpen their technical skills.

While sharpening skills, there are two realities that units must consider. First, aviation skills are acquired by performing the necessary "sets and reps" to become tactically and technically proficient. Second, recent flight school graduates are akin to drivers with a learner's permit when they arrive in their unit. Unit training must focus on newly assigned aviators mastering individual and aircrew tasks before progressing to collective training tasks.

Risk management is integral to the training process. Aviation is inherently risky, and our aviation units can ill-afford to train without managing risk. While our training must be challenging, realistic, and focused on LSCO tasks, units should train with a "crawl, walk, run" approach. As such, formations should accurately report crew training status in their monthly Unit Status Report.

As stated, becoming tactically and technically proficient is essential, but you must also understand how your role supports the combined arms team. We have a sacred trust with our ground maneuver Soldiers and to best support them, we must understand Army doctrine and build relationships with our combined arms teammates as an adjunct to our technical and tactical proficiency.

Conclusion

Army Aviation is undergoing significant change; we are at an inflection point. But we have been here before. In our illustrious history, Army Aviation has successfully undergone changes many times since becoming a branch. This juncture in our evolution is no different. We must capture the lessons learned from our Aviation history and culture and apply them today.

So, the answer to "Are we there yet" is no, but we are on track. We have a plan, and the timelines extend to 2030 and beyond. While we may have deviations, the plan is solid. I am confident that we will meet our goal if we remain focused on the end state.

Be All You Can Be!
Fly Army, Above the Best!

MG Michael C. McCurry II is the Army Aviation branch chief and commander of the U.S. Army Aviation Center of Excellence and Fort Novosel, AL.

BECAUSE GOOD ENOUGH IS NOT AN OPTION.



Ensuring Mission Performance and Aircrew Protection for FARA, FLRAA and the Enduring Fleet

From the first flight until they return home safely on their final flight, Gore is there to help deliver mission success. Today's legacy fleet and tomorrow's advanced rotorcraft are driving the need for high-performance data, power and signal integrity, as well as superior sealing and surface protection technologies.

Our Army aviators benefit from a trusted partner's material expertise and a commitment to failure-free performance and protection in high-vibration and high-temperature conditions. Gore's proven aerospace and defense capabilities include:

- Easy-to-install GORE® SKYFLEX® Aerospace Materials
- Uncompromised performance with GORE-FLIGHT® Microwave Assemblies
- Reliable high-speed data transmissions with GORE® Aerospace High Speed Data Cables
- Precise and repeatable measurements for testing defense systems with GORE® PHASEFLEX® Microwave/RF Test Assemblies
- Class-leading toughness, abrasion and cut-through resistance with our latest innovation of GORE® High Performance Aerospace Wires

To learn more, visit gore.com/futureverticallift

Together, improving life





New Faces, Same Mission in DAMO-AV

By MG Wally Rugen



Bell Textron's V-280 Valor, a joint multi-role (JMR) technology demonstrator (TD), logged more than 200 flight hours during the FLRAA demonstration and risk reduction efforts to help Bell develop the future FLRAA model.

Greetings from the Pentagon, where I'm back for a second tour in DAMO-AV, this time as Director of Army Aviation.

Though the names and faces have changed since I last passed through DAMO, it's a credit to the professionalism of the team and the talent the office continuously attracts that DAMO's mission remains full steam ahead: synchronizing efforts across the Aviation Enterprise; resourcing Army Senior Leader priorities, reporting to Congress; working with industry; and bringing a Total Army perspective to the Aviation Branch.

As the Army shifts its focus to multi-domain operations (MDO), DAMO-AV is laser-focused on fielding MDO-capable aviation units to support the Joint Force. That means sustaining readiness within the current fleet while setting conditions for modernization and a future fleet characterized by additional range, speed, and lethality. DAMO-AV will be hard at work to ensure all efforts across the Aviation Enterprise are synced and mutually supportive of the Army's desired end state.

Modernization

The Future Attack Reconnaissance Aircraft (FARA) fulfills the Army's armed aerial reconnaissance capability gap and delivers an essential capability for conducting large scale combat operations (LSCO) against a peer adversary. FARA, combined with launched effects, forms an ecosystem that serves as the stand in capability for the Joint Force reconnaissance mission with targeting capability in a contested environment. It is the human in the loop for the Division and above echelons and the processing power of the ecosystem.

The Future Long Range Assault Aircraft (FLRAA) is the next generation vertical lift aircraft to be used to conduct air assault and MEDEVAC operations. The fundamental capability of FLRAA is reach and the tiltrotor concept the Army selected will deliver transformational increases in speed and range that are necessary for increasingly dangerous and complex MDO environments.

The Future Tactical Unmanned Aircraft System (FTUAS) is a runway independent, point take-off and landing, rapidly deployable UAS capability to replace the RQ-7B Shadow in the Brigade Combat Teams (BCT). FTUAS provides a distinct advantage over the Shadow due to increased maneuverability through vertical takeoff and landing, improved command and control with on-the-move capability, a reduced transportability and logistics footprint, as well as significantly improved survivability due to a reduced sound signature.

Key to our modernization strategy is adopting a Modular Open Systems Approach (MOSA). MOSA is not a single materiel solution program of record, it is a common approach to all systems. MOSA is our digital backbone – think Android-like, not iOS. It facilitates rapid integration of advanced capabilities, deepens interoperability and provides a quick path to integrating artificial in-



MODERNIZE^{THE} MISSION

THE G5000H™ INTEGRATED FLIGHT DECK UPGRADE

Modern, COTS solution that enhances situational awareness, integrates with mission systems and is backed by global support.

LEARN MORE AT [GARMIN.COM/DEFENSE](https://www.garmin.com/defense)

© 2022 Garmin Ltd. or its subsidiaries.

GARMIN®

telligence. MOSA has the potential to significantly reduce lifecycle operations and sustainment costs for the Army.

Alongside Future Vertical Lift (FVL) aircraft, we know we will be operating our existing fleets of rotary- and fixed-wing aircraft for decades to come. Targeted modernization of the current fleet is necessary to maintain its relevance through 2040 and beyond. The Army is still procuring the newest variants of Apache and Black Hawk helicopters while continuing to develop the newest Chinook variant. In the coming years we will explore opportunities for upgrades to existing aircraft and advancements in sustainment while managing resources to ensure an Aviation MDO-capable force can be fielded to meet Army 2030 requirements.

Training

MDO requires more than just new tech solutions. Across the Aviation Enterprise we are working to modernize how we train and organize ourselves for the future fight.

To ensure we maintain current readiness while building future readiness, Combat Aviation Brigades (CAB) are beginning to execute their training

strategies within the Regionally Aligned Readiness and Modernization Model (ReARMM). ReARMM is the Army's new force generation model. It is simply how we equip, train, and employ our forces moving forward and it goes fully operational beginning in fiscal year 2024. The value of ReARMM is that it optimizes how and when we build and maintain readiness by designating specific windows for modernization within a unit's training schedule. This allows the Aviation Enterprise to efficiently manage when CABs receive targeted modernization while limiting disruptions to training.

Effective preparation for MDO requires rigorous and realistic training at the company, battalion, and brigade levels. At the HQDA level we've increased funding for flying hours across the Total Army to ensure commanders are able to execute their full training strategies. We're also exploring how best to task organize aviation elements to support Combat Training Center (CTC) rotations. The ability of CTCs to incorporate realistic multi-domain challenges into training make them integral to our ability to successfully prepare for LSCO.

Organization

Equally vital to ensuring Army Aviation is an MDO-capable force is optimizing our force structure. Per MDO, Divisions will be the primary combat units of action to conduct LSCO. DAMO-AV is working with Army leadership on options for how Aviation units can best organize to mitigate capability gaps and support Divisions for LSCO.

These are the issues we'll be working hard to push forward in the coming year and I'm excited to get going. I want to thank the outgoing Director, MG Hank Taylor for his capable leadership and guidance during his tenure in DAMO-AV. I look forward to working with our Branch Chief MG Mac McCurry on implementing his vision for Army Aviation. I encourage anyone to reach out to the DAMO-AV team if we can be of any assistance or stop by if you're in the D.C. area.

Above the Best!

MG Walter "Wally" T. Rugen is the Director of Army Aviation at Headquarters, Department of the Army G-3/5/7 (DAMO-AV).



WE'VE STOOD WHERE YOU STAND

For 20 years Frank Reuter served in the Army, first working on military helicopters with the 160th, then fixed wing aircraft with the U.S. Operational Maintenance Support division.

Today, Frank is our Director of Maintenance. A true veteran in aviation, he showcases a natural affinity for the industry and a relentless pursuit of excellence. His experience boldly leads the way.

Frank knows what you demand. **He's stood where you stand.**

summit-aviation.com/stand

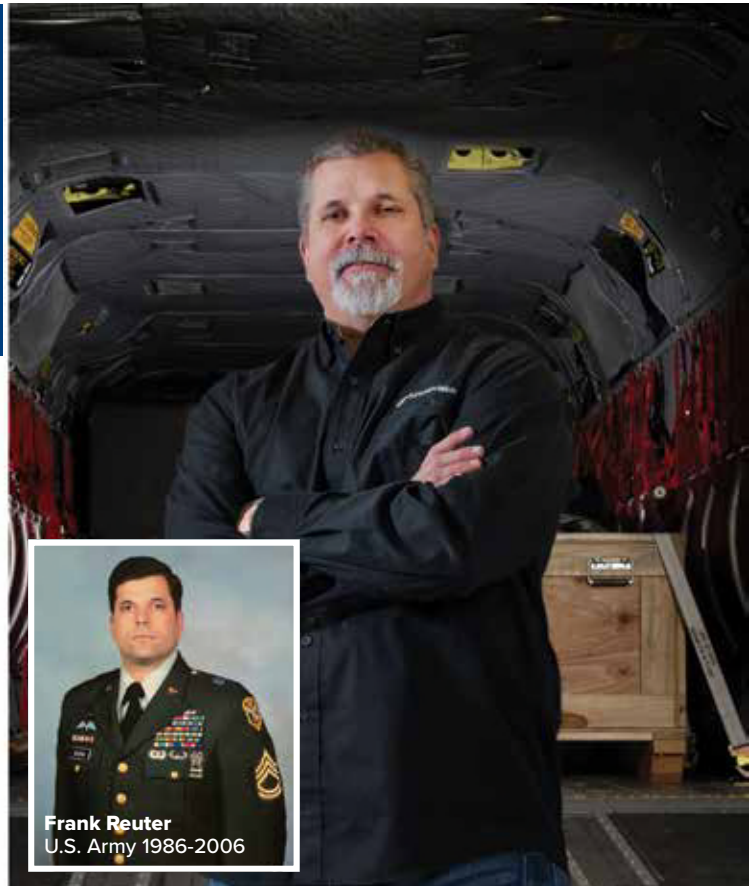

Frank Reuter
U.S. Army 1986-2006

Elevated radio maintenance for operational readiness



CTS-6010

Tester of choice
for the US Marines
HHRTS program



ATS-3100 RTS

Tester of choice
for the US Army
TS-4549/T program

When it comes to preparation, your fleet comes first. The ATS-3100 RTS (benchtop) and the CTS-6010 (portable/handheld) radio test solutions from Astronics help maximize your operational readiness by ensuring your radios perform when needed. With support for legacy, modern, and future technology, our solutions are the ideal replacement solutions for aging and unsupported test equipment.

Contact us today to get started.





► Chief Warrant Officer of the Branch Update

Editor's Note: CW5 Corsaro has asked CW5 Navedo to provide his thoughts on the priorities for unmanned aircraft systems from the DAMO-AV perspective.

Unmanned Aircraft Systems (UAS) Priorities of the Army G-3/5/7 DAMO-AV

By CW5 Keoni Navedo



GENERAL ATOMICS PHOTO

Hello from the Pentagon, where I'm currently in my second tour at G-3/5/7, Department of the Army Operations Aviation (DAMO-AV).

The General Atomics Aeronautical Systems MQ-1C Gray Eagle-Extended Range (GE-ER) unmanned aircraft system.

During my first tour I had the pleasure of working as the UAS Action Officer and DAMO-AV's Executive Officer for three years. Working in DAMO-AV has given me a broad understanding of how Army Aviation synchronizes aviation efforts and future modernization priorities.

UAS Summit

Recently, we participated in the fourth Army UAS Summit at Fort Novosel, AL. The summit allowed discussions on ongoing and emerging Army UAS issues and concerns with the UAS stakeholder community and helped develop solutions and recommendations to senior leaders for decisions. Looking forward, DAMO-AV will work to ensure all our teammates' efforts across the Aviation Enterprise are synchronized with the Aviation Capability Development and Integration Directorate (ACDID) on UAS directed focus areas such as UAS policy and regulations, open system architecture and control, UAS airspace management, UAS support to extending the network, spec-

trum management, and UAS payload target location accuracy.

Future Fieldings

As we continue to support the Army Commands and Army Service Component Commands and act as a conduit for all things Aviation to include the UAS portfolio, one of my main priorities is aligning future fieldings. We are focused on the Future Tactical Unmanned Aircraft Systems (FTUAS) and are tied in closely with our teammates from ASA(ALT), G8 and PM UAS considering the latest Army Modernization Priority List and the Army's Regionally Aligned Readiness and Modernization Model or ReARMM. We will stay the course and field the best, most capable technology to the Army. Key to this effort will be the UAS Project Management Office (PM UAS) leveraging commercial off the shelf products and government science and technology breakthroughs to develop and deliver FTUAS. FTUAS will be a key enabler for BCT cross-domain maneuver, direct

fire and close combat, and aids the BCT in gaining or exploiting positions of relative advantage.

We also must remain focused on our current endurance UAS, the Gray Eagle Extended Range (GEER). Specifically, we will work to support PM UAS in their constant strive to improve the GEER with modifications in Assured Positioning, Navigation, and Timing (APNT), data links, avionics, and re-architecture. Lastly, we continue to support our current Tactical UAS system as we pursue a solution to support our 99 Shadow Platoons that are the primary reconnaissance platform for over 307,000 US Soldiers in every BCT, SFG and CAB.

Above the Best!

CW5 Keoni Navedo is the Department of the Army G-3/5/7 (DAMO-AV) UAS Action Officer in Washington, DC; and CW5 Michael A. Corsaro is the tenth chief warrant officer of the Aviation Branch with the U.S. Army Aviation Center of Excellence, Fort Novosel, AL.



STRENGTH OF PURPOSE

Entrust your most sensitive missions to Gulfstream. With more than five decades of high performance, flexible platforms and proven reliability, there is no other choice for civilian and military operations over land and sea.



Gulfstream[™]

A General Dynamics Company



▶ Branch Command Sergeant Major Update

Editor's Note: CSM Coley has asked SGM Ruben Davila to provide a look into the organization and workings of DAMO-AV and its pivotal role in the Army Aviation Enterprise.

The Role of the Army G-3/5/7 Department of the Army Military Operations Aviation (DAMO-AV) By SGM Ruben Davila



U.S. ARMY PHOTO BY TS/SGT EMELIA WORMANN

Greetings from the Pentagon. Despite twenty-plus years in various organizations within Army Aviation, it wasn't until recently that I discovered that the Department of the Army Management Office Aviation (DAMO-AV) existed, much less knew what it does.

At the junior/tactical level you are so focused on the task at hand that you don't see the bigger picture; hopefully this short article will provide you with a little perspective and a basic understanding of DAMO-AV.

Most AAAA readers know that the home of Army Aviation remains at Ft. Novosel, but the Army's most senior decision makers, resources, strategists and planners all reside in the Pentagon. DAMO-AV is one of the smallest directorates within the seven G-3/5/7 DAMOs. However, there has been a director for Army Aviation in some form or capacity since 1952. Since

aviation is a complex, high demand, and high-cost asset it is important to have a single point of contact within the Army Staff to synchronize and prioritize aviation efforts for the Army. That's DAMO-AV.

Organization

DAMO-AV is broken down into two divisions: Operations and Readiness (O&R) and Modernization. Our small team is comprised of 17 military and 9 government/contract employees. Currently O&R's top three focuses are synchronizing efforts to ensure aviation force structure is optimized for

A U.S. Army UH-60 flies over a grass assault strip during Special Operations Air-Land Integration training near Daugavpils, Latvia, June 28, 2023. Operational readiness is paramount to partnerships, crisis response, deterrence, and support to Allies and partners.

Multi-Domain Operations, sustainment requirements for the current fleet, and ensuring our flying hour program is fully resourced. The Modernization Team's top current priorities are setting conditions for the integration of Future Vertical Lift into the combat aviation brigades (CABs), modernization for our current aircraft fleet and enablers, and providing support to our allies and partners on the integration of our modern aircraft into their aviation fleets. These are just a few examples of what this small team of Aviators do daily.

Today, DAMO-AV is the node for all things Army Aviation in the Penta-

Robertson continues to support the U.S. Army with helicopter fuel systems that extend your range while increasing endurance and time on station.

Extend the reach of your Black Hawk now!



CONFORMAL AUXILIARY FUEL SYSTEM

CAFS (In Development)

1.5
HRS

Increased fly
time
(Dual CAFS)



Average usable fuel
100 gals.



INTERNAL AUXILIARY FUEL TANK SYSTEM

GUARDIAN® SINGLE IAFTS

1.5
HRS

Increased fly
time



Average usable fuel
193 gals.

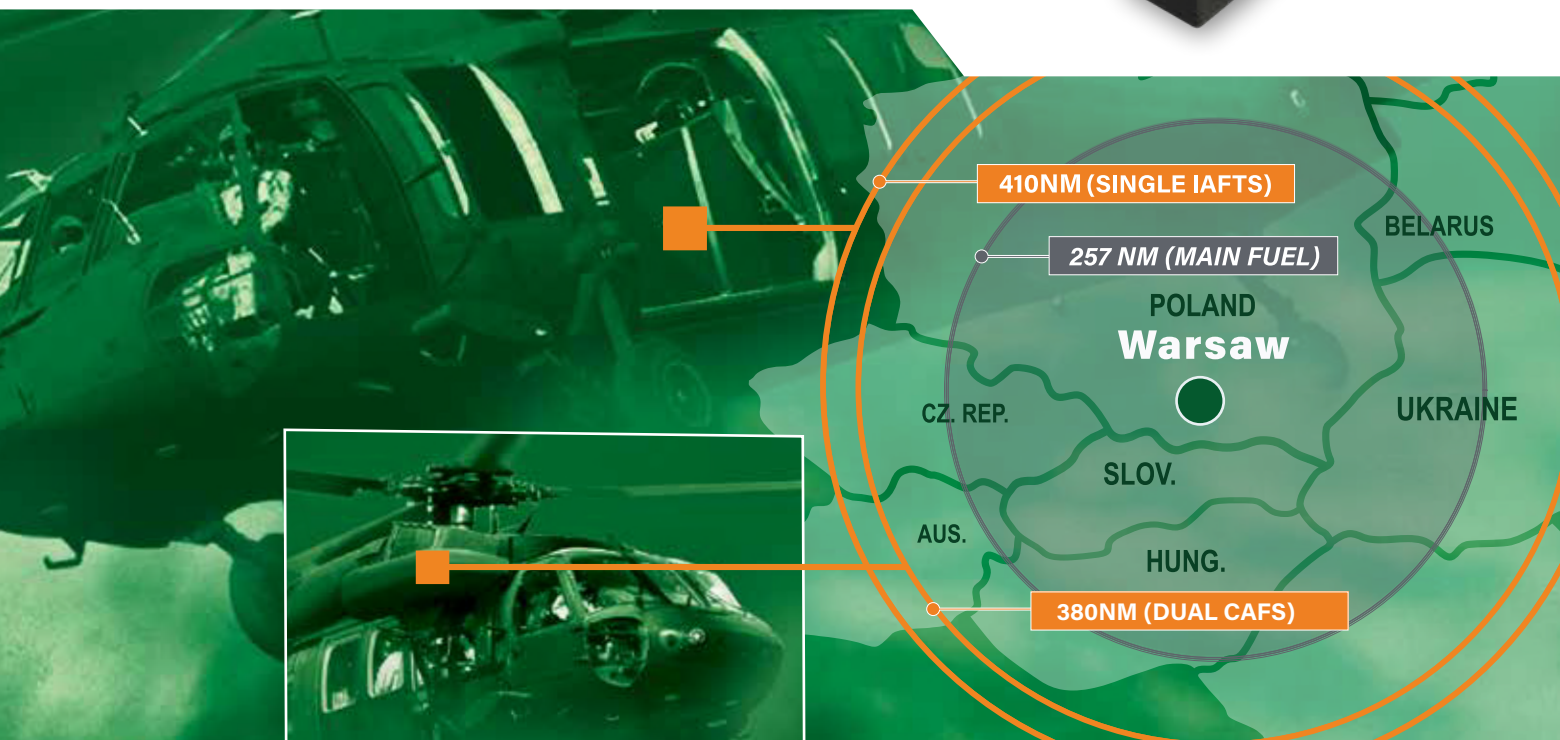

Extend Your Reach Today.

Call (480) 337-8801 or email chip.lunn@robbietanks.com
robertsonfuelsystems.com

ROBERTSON
FUEL SYSTEMS

A HEICO COMPANY

Enlisted Aviation Soldier Spotlight ▶

Each month we will feature a past AAAA National or Functional Enlisted or NCO Award winner as part of our ongoing recognition of the Best of the Best in our Aviation Branch. The CY 2022 National winners were featured in the April/May AAAA Army Aviation State of the Union issue.



AVR FILE PHOTO

UAS Soldier of the Year, 2019

Sponsored by General Atomics Aeronautical Systems, Inc.

SFC Brandon B. Vilt

Company D, 326th Brigade Engineer Battalion,
1st Brigade Combat Team,
101st Airborne Division (Air Assault)
Fort Campbell, Kentucky

SFC Brandon Vilt is a true example of consummate, selfless professionalism. He was entitled to medical retirement in 2007 after he lost his left leg in the line of duty but fought to continue serving. Again, in October 2018, eight months after his third combat deployment, SFC Vilt was entitled to remain in garrison with 2-17 CAV. Instead, when he learned that D Co., 326 BEB needed a Senior Maintenance Chief for deployment to Iraq, he immediately volunteered. He found the company's UAS platoon had an incredibly young maintenance section that had recently failed an ARMS inspection. He enforced his "by the book" standard and turned that section into the best

in the 101st Airborne Division achieving more than 3,000 incident-free combat flight hours and over a 95% Operational Readiness rate in seven months of operations targeting the Islamic State of Iraq and Syria. He was instrumental to the platoon's fully mission capable communications relay system, which provided extended communications for ground forces in Kirkuk, Iraq. Every Soldier in his section is a certified crew chief, he mentored multiple soldiers as technical inspectors, and he sets the standard for fitness. SFC Vilt's professionalism and achievements clearly identify him as the Army Aviation Association of America's 2019 Unmanned Aircraft Systems Soldier of the Year.

gon, and we integrate with all other G3 directorates on a daily basis in support of aviation equities. Our small team of

dedicated professionals cover a wide range of activities for the G3 enterprise and our Army and play a role in

each directorate's mission. Whether it is ensuring we mitigate the impacts of Global Force Management Allocation (GFMAP) requirements on institutional training, ensuring long-term aviation investments align with strategic plans, or determining if our training strategy and resourcing will produce the required readiness levels, DAMO-AV is there. The Aviation Directorate also spearheads aviation-related efforts across the Army Staff. Actions like Aviation retention, equipment readiness metric reform, and procurement strategies all reside in DAMO-AV's daily portfolio. Our small team also serves as the lead integrator for industry engagement in the NCR and is regularly called upon to discuss Army equities on Capitol Hill.

It is important as leaders that we understand the resources available to the aviation community and synchronize our aviation efforts in order to prepare our Soldiers for the next fight. DAMO-AV is integral to that effort and a key member of the larger Aviation Enterprise.

SGM Ruben A. Davila is the Department of the Army G-3/5/7 Sergeant Major; CSM Kirk Coley is the command sergeant major of the Aviation Branch at the United States Army Aviation Center of Excellence, Fort Novosel, AL.



YOUR READINESS IS OUR FIRST PRIORITY

BRINGING BEST-IN-CLASS AVIATION SERVICES TO OUR MILITARY PARTNERS

- Global aerospace maintenance, repair and overhaul support for aircraft, rotorcraft, engines & avionics.
- Complete engine MRO for GE T700/CT7, Pratt & Whitney Canada PT6A, PT6T, PW200 Rolls-Royce T56, AE2100, AE1107, and M250
- Full engineering, design and certification capability, including reliability-based and predictive maintenance.



CONTACT US

standardaero.com/governmentmilitary





The Proven Choice for the Army National Guard.

The TDFM-9000 Series radios offer technology built for today's most demanding operations. Plus, its fully scalable and modular design allows you to buy only what you need today and still be ready for whatever the mission throws at you tomorrow.

TECHNISONIC
COMMUNICATIONS





Risk Management Culture

By LTC Sean O'Connell

People often talk about having a risk management culture / climate, but they rarely talk about what that means.

I think everyone knows what that climate feels like, as it often goes hand in hand with a positive or poor command climate. When it comes to risk management, DOD Human Factors taxonomy states that an organizational culture can set the conditions that “allow an environment in which unsafe task/mission demands or pressure exist” and is a factor when “explicit/implicit actions, statements or attitudes of unit leadership set unit/organizational values (culture).” While this focuses on the negative aspect of culture, culture can also create a positive atmosphere of cohesive units that are well-trained professionals ready to execute missions safely and to standard.

Soldiers intuitively know there is no effort without error, and a command climate that values initiative accepts this. The concept of risk management also accepts actions, even those that are well-planned, inevitably entail the risk of being wrong. On the other end of the spectrum, an organization with a poor climate hides its mistakes out of self-preservation rather than learns from them. The mandatory Army Readiness Assessment Program (ARAP) survey that battalion commanders take at the beginning and midway through their commands (<https://earap.safety.Army.mil>) is a powerful tool at a unit’s disposal. Interestingly, units that report the least Class C and below mishaps have the most Class A mishaps, while units that score the best are the opposite. Additionally, units that score in the bottom 25% account for more than 50% of Class A mishaps.

As Dr. Timothy D. Ludwig stated in his book, “What Are You, Stupid!?: Dysfunctional Practices that Kill



your Safety Culture (and What to do about Them),” culture is measured by what people talk about. He describes talking about risk as the key ingredient to knowing what is happening in your organization and reducing at-risk behavior. Only then can an organization identify the risk and analyze the reason why the person was in the position to take the risk. All of this with the goal of creating a culture where peers coach peers when they see risky behaviors and praise each other for managing risk.

After taking stock of our culture, how do we then bridge the gap between knowing what to work on and doing it? In the book “The Knowing-Doing Gap,” authors Jeffery Pfeffer and Robert Sutton have eight guidelines for action that are paraphrased below, with how it relates to the leadership philosophy of Mission Command, in parenthesis:

1. Put the Why before How (**Commander’s Intent**) – A general guidance for action is important so personnel know how to adapt to different situations.
2. Knowing Comes from Doing and Teaching Others How (**Competence**) – Apprenticeship and mentoring.
3. Action Counts More than Elegant Plans and Concepts (**Disciplined Initiative**) – Don’t let planning, decision-making, meetings and talk substitute for implementation.
4. There is no Doing without Mistakes (**Risk Acceptance**) – Reasonable failure should not be

received with retribution.

5. Fear Fosters Knowing-Doing Gaps (**Mutual Trust**) – Fear starts, or stops, at the top.

6. Fight the Enemy, Not Each Other (**Mission Orders**) – People prefer collaborative and cooperative work arrangements.

7. Measure What Matters and What Can Help Turn Knowledge into Action (**Shared Understanding**) – Ensure everyone understands the key measures of success with intermediate outcomes and in-process indicators.

8. What Leaders Do, How They Spend Their Time and How They Allocate Resources, Matter (**Mission Command Philosophy**) – Leaders create environments, reinforce norms and help set expectations through actions and words.

Training and talking to our personnel about nesting Mission Command with a risk management culture will help create a positive climate that prevents “an environment in which unsafe task/mission demands or pressure exist” or as Army Doctrine Publication 6-0 puts it: “Employing the mission command approach during all garrison activities and training events is essential to creating the cultural foundation for its employment in high-risk environments.”

LTC Sean O'Connell is the Aviation Division chief in the Directorate of Analysis and Prevention in the U.S. Army Combat Readiness Center, Fort Novosel, AL.

MOOG

WEAPON STORES MANAGEMENT, LAUNCHERS, & SIMULATOR SYSTEMS

AGILE
MODULAR
DIGITAL
AWR PROVEN
FUTURE WEAPON CAPABLE

Photo Credit: Fulcrum Concepts, LLC.



Gun Rocket Unit (GRU)



Lightweight DRL with Trident LGR-3 Launcher



Enhanced Stores Interface Unit (E-SIU)



Enhanced Stores Management Computer (E-SMC)



Weapon Control Panel (WCP)



Customizable EFIS Primary Flight and Multi-Function Displays



Missile Simulator on Dual Rail Launcher



SCAN TO LEARN MORE AT MOOG.COM





Aviation Facilities – Where All Things Aviation Start and End

By LTC Aaron Schilleci



U.S. ARMY PHOTO BY SPC BERLAIN CORNE, ARNG

ARNG Aviation Facilities often serve not only as a flight facility, but the de facto Readiness Center, where Aviation Soldiers report for duty and training throughout the year.

SPC Jonathan Bryant, C/1-376 Security and Support Aviation Battalion and Mr. Robert Unger, ARNG Regional Aviation Phase Support Center contract employee conduct aircraft maintenance in the Kentucky ARNG Aviation Support Facility, Frankfort, KY.

The Aviation Facilities in many cases are a hangar or a set of buildings built solely for ARNG Aviation, or in some locations, a building made available through lease or obtained from other Department of Defense Agencies, Activities or Services.

The ARNG Aviation Facility Snapshot

Across the 54 States, Territories, and the District of Columbia, the ARNG operates approximately 294 buildings that support Aviation with a capacity of about 9.9 million square feet and on average about 33 years of age. This significant infrastructure is attributed to the fact that the ARNG possesses nearly half the Army's Aviation operational capability. The number of Aviation facilities in each State, as you would expect, is relatively proportional to the

State's Aviation footprint e.g., California and Texas have three or more facilities. Of the 294 Aviation buildings, 104 are identified as either a full ARNG Aviation Support Facility (AASF); a Limited AASF, a Tactical Unmanned Aircraft Systems Operational Facility, a Theater Aviation Support Maintenance Group, or an ARNG Aviation Training Site. The remaining Aviation buildings include smaller temporary storage buildings or other support buildings. The AASF, as the most predominant facility, will typically consist of a building / hangar that houses one or more units. Of course, all the facilities and various other buildings fulfill specific roles across the ARNG Aviation spectrum to include not only housing units and aircraft but supporting operational, sustainment and institutional training requirements.

Building Buildings—The Aviation Facility Process

Like the Active Army and Army Reserve Aviation, the ARNG primarily utilizes Military Construction (MILCON), along with other funding streams such as recapitalization funds for building new Aviation Facilities, upgrading existing buildings and other minor construction projects. ARNG Aviation is one of many facilities stakeholders and therefore must compete with other ARNG MILCON requirements. MILCON is a lengthy difficult process within the Fiscal Year Defense Planning cycles and like other funding, it can be decremented based on changing priorities and budgeting shortfalls. The ARNG G-9 is the National Guard Bureau (NGB) Staff Lead for Installations and manages the ARNG's inputs to the Army's Installation Program Evaluation Group. The NGB Aviation

and Safety Division maintains representation within the ARNG G-9 processes to articulate and integrate Aviation Facility priorities.

Many of the ARNG's current facilities were built in locations and population centers dating as far back as the 1950s, which effectively supported recruiting, retention and operational needs at the time of construction. However, population centers within many states continue to shift over time. The Active Army has the advantage of utilizing a Permanent Change of Station Order to move personnel to a specific number of Army Installations, whereas the ARNG essentially assigns (stations) the unit / aircraft to the right locations, which can support the manning and operational demands of a unit, while also supporting ever fluctuating employment needs of National Guard personnel.

In the FY 24 Unfunded Priorities List (UPL), the Services acknowledged a need for greater amounts of funding to keep pace with the demand for building and sustaining facilities. Typically, the UPL outlines a need for Weapons Systems, so identifying facilities is an indication that facilities are underfunded.

Facilities & Readiness – Balancing Competing Challenges

The Army and the ARNG face an enormous number of recruiting and retention challenges into the foreseeable future. As more states assess the best locations for their ARNG Aviation capabilities to support these recruiting and retention challenges, there will be a subsequent rise in the number of states seeking to either establish new facilities or relocate / recategorize current Aviation facilities. The ARNG's Aviation Facility locations are critical to overall unit readiness and support to the Director, ARNG's 2030-2040 Vision. Therefore, it's incumbent that NGB and the ARNG Aviation Team seek to continually optimize Aviation facilities posture to keep pace with evolving national demographics while concurrently integrating the emerging needs of manned and unmanned variants within the family of Future Vertical Lift capabilities.

ARNG Aviation – Warfighting Capable, Governor Responsive!

LTC Aaron Schilleci is the new chief of the Army National Guard Aviation and Safety Division.

Register Today!



AAAA Cribbins Readiness Conference

November 13-15, 2023

Von Braun Center, Huntsville, AL

quad-a.org/23CRIBBINS

2024 SUMMIT

ARMY AVIATION MISSION SOLUTIONS SUMMIT

April 24-26, 2024 | Denver, CO | quad-a.org/24SUMMIT

Register and Secure Housing Today!





▶ 128th Aviation Brigade Update



128th Aviation Brigade Soldiers Triumph on the International Stage

By SSG Charles Hayworth and SSG Audley H. Rumble



1st Place Team Black Hawk – (left to right) SSG Rumble, SSG Gatson, SSG Portillo, SFC Jenkins, SSG Parker, and SSG Hayworth.



3rd Place Team Chinook – (left to right) SSG Hagler, SSG Chanchompoo, SFC Rogers, SSG Swift, SSG Clements, and SSG Call.

Army Aviation plays an integral role in fighting our nation's wars and it must remain prepared to do so into the future.

Part of that role is precision maintenance, in Aviation this is something that needs to be cultivated; it is a fine blend of quality, speed, accuracy, and knowledge. This precision training begins in the 128th Aviation Brigade and continues throughout the career of the maintainers. Aviation capabilities are an essential element in support of units, and our maintainers need to be prepared to maintain Fully Mission Capable (FMC) fleets worldwide.

During the annual Aerospace Maintenance Competition (AMC) held in Atlanta, Georgia, the 128th Aviation Brigade supplied two teams of 6, Team Black Hawk and Team Chinook. The AMC is an annual event that brings together Aviation maintenance teams from across the globe. There were teams representing Aviation trade schools, teams representing companies from places like Australia and Brazil, military Aviation teams from the U.S. and abroad, and major commercial teams from recognizable names such as American Airlines and United. 84 5-man teams competed in 26 events, each with a time limit of 15 minutes. The events were all unique, with teams being asked to perform various tasks including the replacement of an aircraft window, an aircraft avionics modification, the rigging of an aileron, the replacement of a cargo floor lock, and an engine fan blade removal.

The competition is a week-long event, where the first four days involved tasks out of technical manuals and the final day involved a written exam. Training for the competition involved practicing tasks that are in the 128th program of instruction

as well as maintenance tasks that are currently being practiced in the fixed wing industry. Most of the events were based on fixed-wing aircraft and because most Army Aviation is rotary wing, the maintainers did not have access to those aircraft prior to the competition. The teams were comprised of various MOSs including Airframe, Hydraulics, Armament, Avionics, Propulsion, Powertrain, and of course your jack of all trades the "crew chiefs." Many of the practice sessions involved just reading over the task and researching the different aircraft parts to gain as much knowledge as possible. Among the 18 military teams that competed, Team Black Hawk won 1st place and Team Chinook won 3rd place. Additionally, out of the 84 teams that competed, Team Black Hawk was placed 18th overall. SSG Parker Curtis from C Co 2-210th was the fastest competitor to use an E-Drill in the competition's history.

Our aircraft maintainers are the controlling center of our Aviation workforce, and with deliberate modernization of the program of instruction taught in Army Aviation, Army Aviation will continue to support missions worldwide and develop more agile and expert maintainers to lead and train our Combat Aviation Brigade's maintenance programs. The goal is two-fold, the first is to win, the second is to promote Army Aviation as a major generating force to the civilian aerospace sector. It is a gateway for Soldiers to learn a trade and develop skills while serving their country. Used appropriately, the Army's participation in the AMC could be a highly valuable recruiting tool. Not only did the 128th Aviation Brigade prove that they could compete with the best in the Aviation industry, but they also proved that they are among the best in all military Aviation.

Born Under Fire!

SSG Charles Hayworth is an AH-64 maintenance instructor and SSG Audley H. Rumble works as a system developer (NISB-E) for the 128th Aviation Brigade at Joint Base Langley/Eustis, VA.



TRUST EARNED DAILY

**Hard-working rotorcraft hand built by
a hard-working organization.**

History favors the bold and time reveals trust. As we approach 70 years in business, we've undergone many dramatic evolutions. Some beneficial. Others less so.

We now have an opportunity to rebuild and sustain our legacy. With new leadership and a focusing vision, we are moving boldly ahead.

WE'RE READY TO DO THE WORK.



MD | HELICOPTERS™

480.346.6300 / mdhelicopters.com

How Big is the Bird?

Bird Strike Requirements for Large Rotorcraft

By Ms. Tia Larsen-Calcano and Mr. Huy “Ken” Hoang

Airworthiness requirements are based around the concept of design assurance. We have requirements for assurance of software testing pedigree, structural integrity, and even protection from environmental hazards.

However, to protect against a hazard in the environment, one must first understand, define, and scope the intended environment for which to protect from and understand that force protection requirements may change. We can’t change the environment and for military applications, we can’t change the scope of the environment for which we fly, but by defining and understanding environmental hazards, we can implement design requirements that protect against some of the “knowns.”

This understanding and assessing process is currently being reviewed for the bird sizing requirement for a windshield bird strike test. Currently, the Federal Aviation Administration (FAA) requirement for bird strike is to test for a 2.2 lb. bird per 14 CFR 29.631 while the Army requirement is 4.0 lbs. according to MIL-I-81752, ASTM F330, and the Army Military Airworthiness Certification Criteria (AMACC). However, as the Army looks to Future Vertical Lift and the FAA looks to Urban Air Mobility and electric Vertical Take-Off and Landing (eVTOL), the operating environment for large rotorcraft begins to change with an increased prevalence of lower altitude flight and likely increased velocities. Bird strikes currently tend to occur primarily in the critical phases of flight (take-off and landing) at lower



U.S. ARMY PHOTO

altitudes, so as the aviation community increases operation at these lower altitudes, it is expected that frequency and rate of occurrence will increase.

First, we must understand what the current issue is that is being discussed. There are two prongs to assessing the credibility of a hazard, likelihood of the incident and the consequence of the associated failure. When assessing likelihood, this office utilized the public FAA wildlife database for bird strike incidents from 2000 to 2020 to identify over 200,000 bird strike incidents with approximately 26,000 striking the windshield. Of those, approximately 1,000 of those strikes were labeled as being induced by a large bird with 25% of those incidents resulting in damage to the windshield. The consequence of failures associated with these events very seldom result in aircraft destruction, but instead result in a reduction in visibility and/or windshield fragmentation into projectiles in the cockpit. Although aircraft destruction is rare, it does occur.

Second, it is important to understand how bird strikes are evolving based on the new flight envelope. Birds, especially large birds, tend to fly at low altitudes in southern states with Florida having the highest quantity of reported bird strike incidences. These incidents usually occur during the critical phases of flight,

take-off, and landing, and often occur near water with 84% of windshield bird strikes occurring below 10,000 feet. Coincidentally, the southern United States is also home to the highest population of actively certified pilots with the FAA (125,000 out of 757,000 total based on 2022 statistics). This high density of pilots combined with the increased flight hours occurring under 10,000 feet are not a hazard in itself but combined with the bird strike rate the preconditions for an accident begin to stack up.

There will always be unpredictable environmental hazards that occur in aviation that designers are unable to control, but there are known conditions which we can expect. Birds will always be a prevalent and ongoing concern for our Aviators, and with the increased flight envelope expanding to lower altitude flight, it is time to revisit the existing bird sizing requirement for the windshields. With increased flight hours at low altitudes and such a high pilot population in the most bird-prevalent states, bird strikes will continue to be a major concern for our Aviators.

Ms. Tia Larsen-Calcano is an engineering physiologist and Mr. Huy “Ken” Hoang, an electronic engineer both with the AvMC Systems Readiness Directorate, Redstone Arsenal, AL.

**MISSION
CRITICAL
COMMS**



INDUSTRY-LEADING

**DIGITAL
AUDIO
SYSTEMS**



P139-HD

DIGITAL AUDIO SYSTEM



Ask about available STCs



LSS220



LSS440



LSS880



LSC22

Distributed by



LINX Procedure

By MAJ (Dr.) Devon Greer

Q: “Hey, Doc, I’m considering the LINX procedure. Can I fly after it?”

FS: Let’s look at the background of the LINX procedure. The LINX procedure is a treatment for Gastroesophageal Reflux Disease (GERD), more commonly known as heartburn. GERD occurs when the sphincter at the bottom of the esophagus is too relaxed and allows stomach acid to “reflux” back up the throat causing burning, pain, and changes to the lining of the esophagus. The LINX Procedure is generally reserved for people who have more severe symptoms than the occasional episode after eating at your favorite spicy food joint – it’s intended for those who need near-constant medication to suppress acid or medications don’t work. Long term, or chronic, GERD causes irritation to the esophagus, and over time can progress to changes in the esophagus resulting in cancer. Medications treating

GERD focus on reducing acid in the stomach to protect the lining of the esophagus and halt the progression towards cancerous changes. These work very well for most people, but don’t change the underlying cause of GERD.

The LINX procedure works by attempting to correct the lower esophageal sphincter that allows stomach acid into the esophagus. It is an alternative to a surgical procedure called a Nissen Fundoplication, which treats severe GERD by wrapping a section of the stomach around the esophagus to tighten the lower esophageal sphincter and prevent stomach acid from entering the esophagus. The LINX Procedure works in a similar fashion but places a ring of magnets around the lower sphincter to tighten it without using a stomach wrap. The magnets create a snug but expandable ring at the level of the sphincter, helping it stay closed but still allow swallowing. The LINX procedure is a surgical solution, requiring a trained surgeon to place the device and time to heal. After healing, it tends to be effective in preventing GERD symptoms.

Every medical procedure or medication has some level of risk, and the LINX procedure has some specific risks. It may

DLA Into-Plane Refueling Contract

David Wayne Hooks Airport

(KDWH) One of the largest private airports in the United States, specializes in military aviation services.

Open for Operation 24 | 7 | 365:

- On-site Restaurant
- Meeting facilities
- 15 minute quick turn service with minimal ground delays
- Weather and flight planning facilities
- Military briefing rooms
- Pilots lounge



Currently Seeking a Rapid Refuel Sponsor

Gill Aviation
Your Trusted Source in Houston

(KDWH) | Houston, Texas | 800.624.7394

Scan Me!



not fully control GERD symptoms and may not completely prevent stomach acid from refluxing into the esophagus. Other common risks occur around the placement of the device, including infections, pain, and discomfort. It may be too tight and make it difficult to swallow (or burp to relieve the air in the stomach at higher altitudes). The device can also migrate, so it is not in the right location to control GERD. These issues can be severe enough to require a second operation to remove or modify the device. The greatest threat may be that it can erode the esophagus and cause leakage of the stomach contents and acid into the surrounding tissues. This is a serious condition that causes incapacitating pain and illness, but rarely occurs. A pilot should expect to be well healed from any surgery before being considered safe to fly. This surgery is a large procedure, and even uncomplicated implantations won't be considered completely healed for several months. Surgeries that experience complications may not completely heal for even longer. Despite these risks, the LINX procedure is generally safe and has a relatively low rate of significant problems.

The LINX procedure now has several years of history behind it for control of reflux; however, there is less information regarding pilots. Although most people experience substantial relief of their reflux with minimal or no side effects, pilots have uncommon stressors. The device may make it more difficult to handle pressure changes, particularly with the air expansion in the stomach, which can be distracting. The device could potentially shift, break, or fail which could be problematic in a critical phase of flight. Additionally, there is no published information on whether the magnetic field in the device could interfere with flight or navigational instruments. Despite concerns about the effects and complications, a handful of pilots have now been approved to fly with the device.

There are many options to control severe heartburn, and the LINX procedure is growing in popularity. Although there is little data on its effect on pilots, its relatively low rate of complications makes it an attractive treatment option. While this device is not permanently grounding, pilots with the device are unlikely to be cleared for flying duties until completely healed and enough time passes to prove there are no unexpected outcomes. The length of time necessary to have the procedure and heal must be accounted for by prospective patients, particularly in commercial pilots who rely on flight to receive pay. The presence of a LINX carries its own risk, but also is an indication of the severity of the underlying GERD present in the pilot prior to the operation. Close coordination with your flight surgeon about current symptoms, expected outcomes, and follow up after implantation will help your flight physical go more smoothly.

Fly Safe!

Questions for the Flight Surgeon?

If there is a question you would like addressed, email it to AskFS@quad-a.org; we will try to address it in the future. See your unit flight surgeon for your personal health issues. The views and opinions offered are those of the author and researchers and should not be construed as an official Department of the Army position unless otherwise stated.

MAJ Devon Greer, MD, is an aerospace medicine physician at the U.S. Army Department of Aviation Medicine, Fort Novosel, AL.

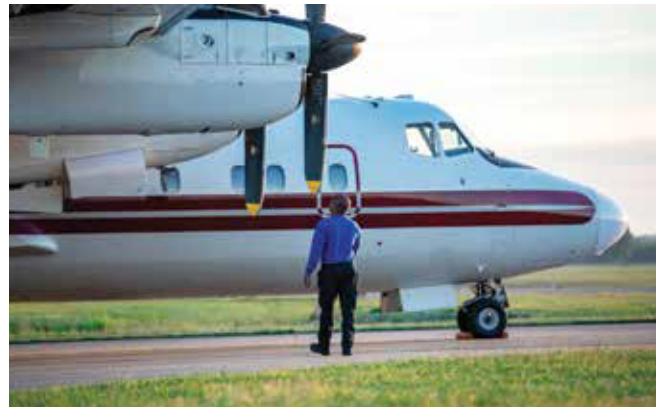

ANYTIME ANYWHERE

WE MAKE IT HAPPEN

KING AEROSPACE



972.441.2423 > KingAerospace.com

Complete Support for ROTOR BLADES, ROTOR HEAD & LANDING GEAR



AVIATION BLADE SERVICES, INC.

PIEDMONT PROPULSION SYSTEMS, LLC

HELIBLADE INTERNATIONAL, LLC

AAMSI

First Aviation Services Inc.®

+1 203.291.3300 | firstaviation.com



European North Atlantic Treaty Organization Helicopter Pilot Training Program

By Mr. Sam Baker

If you have ever been a student or graduate student pilot on one of the flight lines at Fort Novosel and flown with a European instructor pilot, then you likely have experienced the primary mission of the European North Atlantic Treaty Organization Helicopter Pilot Training Program (ENHPTP).

The Euro-NATO Helicopter Pilot Training Program is a relatively quiet program of exchange between six countries and resides within 110th Aviation Brigade at Fort Novosel and the United States Army Aviation Center of Excellence. The program is executed under a Memorandum of Understanding (MOU) between The Ministry of Defence of the Kingdom of Denmark, the Federal Ministry of Defence of the Federal Republic of Germany, the Ministry of Defence of the Italian Republic, the Minister of Defence of the Kingdom of the Netherlands, the Ministry of Defence of the Kingdom of Norway, and the Department of Defense of the United States of America.

The ENHPTP is an outgrowth of the September 1970 EURO-NATO Training Conference held in Brussels, Belgium. In April 1972, Canada, Denmark, Germany, Italy, Netherlands, Norway, United Kingdom, and the United States formed a working group to make recommendations to the October 1972 EURO-NATO Training meeting at The Hague. The working group conclusion that a multinational basic helicopter pilot training school was both desirable and feasible was briefed. The full EURO-NATO Training meeting concurred in continued investigation with emphasis placed on obtaining more precise cost and execution data. Subsequent working group meetings resulted in a finalized Memorandum of Understandings (MOU) signed with Denmark, Germany, and Norway in October 1975; The Netherlands officially joined the program in 1977 and Italy in 1998.

The mission of the ENHPTP is to as-



ENHPTP IPs work with both international and U.S. Army students in the 110th Aviation Brigade at Fort Novosel, AL

sign instructor pilots (IPs) from foreign countries to the 110th Aviation Brigade under the authority of the ENHPTP MOU to assist USAACE in meeting its mission of training 1,436 Initial Entry Rotary Wing (IERW) flight school students and more than 2,201 graduate students in multiple courses to include Advanced Aircraft Qualifications, Instructor Pilot and Maintenance Test Pilot Courses. The 110th Aviation Brigade Commander is the approval authority for each IP nominated by one of the participating countries before entering training and ultimately utilization as an IP on one of the five flightlines at USAACE. Most of the IPs are trained and qualified in the United States Army aircraft, however not all countries retain the same mission design and series (MDS) of aircraft, therefore the commander of the 110th Aviation Brigade and their Standardization team evaluate the qualifications of the nominee. Much like a United States Army Aviator, the assessment and qualifications are the same and at times an Aircraft Qualification Course is scheduled followed by an Instructor Pilot Course.

The ENHPTP has a Steering Committee (SC) that meets annually on a rotational basis throughout the participating countries, and it determines the number of IPs from each country that will be assigned to USAACE and the 110th Aviation Brigade. Once a nominee has been approved by the 110th Aviation Brigade Commander and allotted, they serve a minimum of two years, usually up to three and upon occasion may be extended further if all entities agree. The objective of EURO/NATO participation in training at USAACE is to enhance the standardization, rationalization, and interoperability of the NATO Alliance with the United States.

The SC consists of one representative, the Senior National Representative (SNR), selected by the national authorities for each participating country and additional national representatives may attend the annual SC meeting. The United States has several representatives besides the 110th Aviation Brigade in the SC which includes the Security Assistance Training Field Activity (SATFA) and the Office of the Deputy Assistant Secretary of the Army, Defense Exports



DC ONE-XM  

**C-130, KC-135, C-5
ANR Model**

Low Impedance

NSN# 5965-01-684-5485
P/N 43102G-03



DC ONE-XM  

C-17 ANR Model

High Impedance

NSN# 5965-01-680-0088
P/N 43102G-09





DC ONE-XM  

C-130J ANR Model

Low Impedance

NSN# Pending
P/N 43102G-10



DC PRO-X₂  

KC-10 ANR Model

High Impedance

NSN# Pending
P/N 43105G-05



Air Dominance

Next Generation Air Crew Headsets

David Clark Company has been a leading supplier of aviation headsets for the US Armed Forces and military aviators worldwide for decades. These purpose-built air crew headsets are designed to match the impedance and connectivity requirements for a variety of military aircraft. Offering lightweight comfort, excellent active noise reduction performance and “David Clark durability”. For more information call **1-800-298-6235** or visit **www.davidclark.com**.



U.S. ARMY PHOTO BY CHRISTINE SWAGER

and Cooperation (DASA DE&C). The main purpose of the steering committee is to exercise executive-level oversight of the ENHPTP, monitor annual national training requirements and approve any changes to the MOU or its annexes. Additional meetings may be held at the request of any country, however, the

110th Aviation Brigade currently holds a quarterly Multi-National Synchronization (SYNC) meeting that discusses all topics and concerns of the ENHPTP. The 110th Aviation Brigade through the ENHPTP has incorporated the 1st Aviation Brigade and its International Military Student Office (IMSO), the

The 2023 ENHPTP Annual Steering Committee in Nashville, TN.

USAACE G2 Intelligence, the USAACE G5 Strategic Initiatives Group (SIG) and other units on Fort Novosel in the Quarterly SYNC Meeting. The quarterly SYNC not only addresses issues concerning the ENHPTP, but all foreign issues, topics and discussions surrounding the execution of Army Aviation flying utilizing foreign IPs and their students. The ENHPTP instructors provided do not only fly foreign students, but mainly train US students of IERW flight school.

Currently the ENHPTP has 22 agreed upon positions and utilizes Denmark in the UH-72, Germany in the UH-60M/UH-72, Italy in the CH-47F, the Netherlands in the CH-47F, AH-64E and UH-72 and Norway in the UH-60 and UH-72, respectively. The ENHPTP instructors are some of the finest and assist the 110th Aviation Brigade in safely training 3637 students while flying 220,474 hours which equates to 27% of the total flight hours for the US Army worldwide.

This year the ENHPTP Annual SC meeting was held in conjunction with the Army Aviation Association of America's Army Aviation Mission Solutions Summit in Nashville, Tennessee from the 23rd through the 26th of April 2023 and will be hosted by Italy next year.

Mr. Sam R. Baker is the deputy operations officer (DS3) and foreign liaison for the 110th Aviation Brigade, U.S. Army Aviation Center of Excellence, Fort Novosel, AL.



Pain-Free Flying for Aircrew Endurance

Upgraded "AWR Approved" Seat Cushions

**H-60
Blackhawk**

**AH-64
Apache**



**CH-47
Chinook**

**OH-6
Little Bird**

View a Full Range of US Army "AWR Approved" Products On our Website and Order Now!

Coastal Seat Cushions, Inc
 Email: Sales@CoastalSeatCushions.com
 Tel: (954) 980-6929



Army Aviation:

MARK LIKE A PRO

THE PHANTOM SENTRY™ SAVES LIVES.



ATTACH IT TO A TENT:
SAVES SOLDIERS FROM GETTING RUN OVER
WHILE SLEEPING.

ATTACH IT TO A PACK:
TEACHING LAND NAV? KEEP AN EYE
(VISIBLE OR IR) ON THOSE TRAINEES!

ATTACH IT TO A HELICOPTER:
NO ONE SHOULD CRASH INTO ROTORS OR ANY
OTHER PART OF THE AIRCRAFT THEY CAN'T SEE.

ATTACH IT TO A TRUCK:
EVERY TIME A SOLDIER IS SLEEPING NEXT TO IT.

ATTACH IT TO A MEDIC/PATIENT:
HEADING UP OR DOWN THE LINE AT NIGHT.

The Phantom Sentry™ is a compact, rechargeable marker light that attaches to an individual tent, a vest, a tree, a truck or anywhere else you need reliable longer-term lighting to keep Soliders safe.

Basic specs:

- *Visible/IR/alternating modes
- *Rechargeable with USB-C
- *Lasts 3 weeks on a full charge
- *Dark activated mode



Phantom Products, Inc.

Designed and Built in Rockledge, Florida USA
PH: (321) 690-6729
CAGE 3WQN8

* Small Business * Made in USA * ISO9001:2015 Certified *

©2023 - Phantom Products, Inc.
careers@phantomlights.com



www.PhoantomLights.com

► From the Field

Readily Available Information Technology Tools Improve Retention and Readiness

By MG (Ret.) Tim Gowen, and COL (Ret.) Rich Ferguson

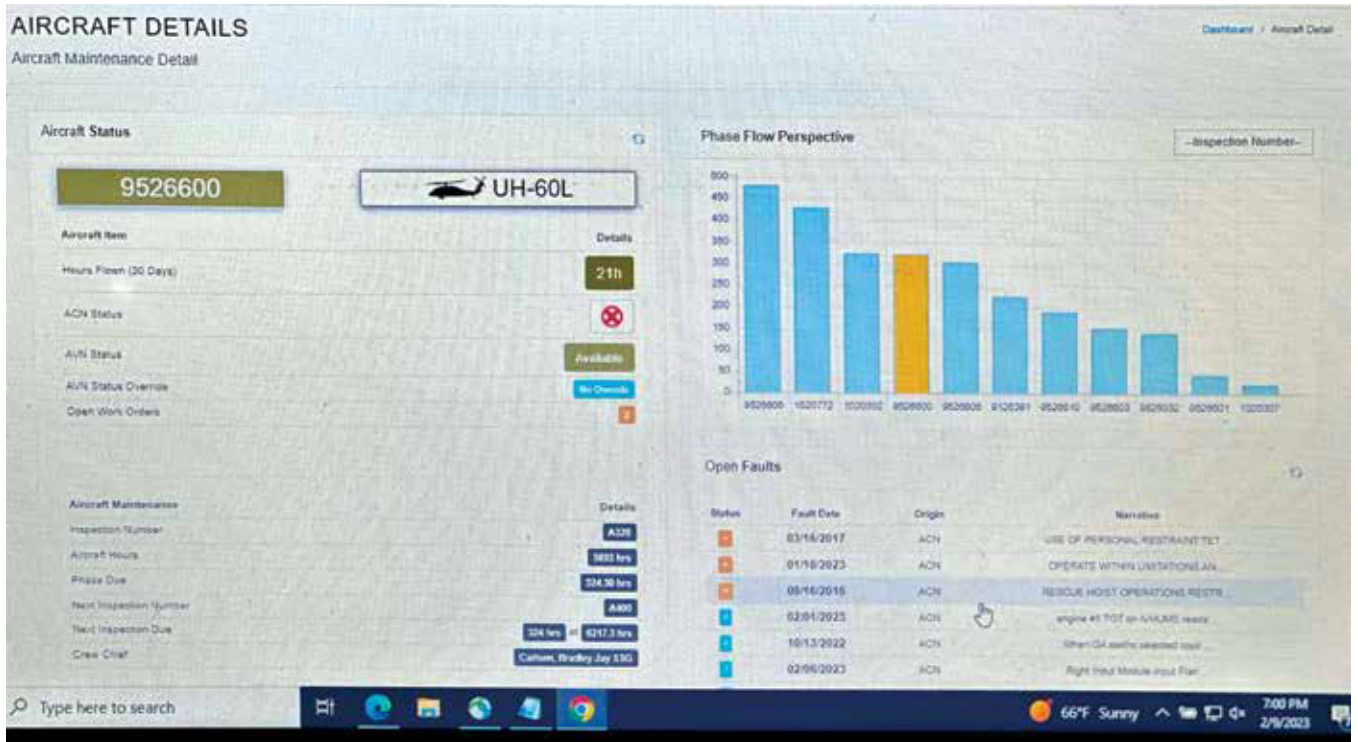

Aircraft dashboard details.

Army Aviation is one of the most competent and capable warfighting enterprises and operational organizations in the United States military. We provide our Soldiers the mobility and lethality they need to fight and win our nation's wars better

than any other branch. But we can be better. Unfortunately, our highly professional Aviation units are stymied with inefficiencies that waste valuable time and money because we're forced to rely on "tried and true" antiquated processes to organize the data that inform import-

ant decisions. *It's time to switch to new technologies that will improve situational awareness by providing access to real-time aircraft and flight-status data.*

"Source of truth" data – raw, trustworthy facts and figures we use to feed our higher-level information systems – has historically been difficult to reliably acquire, maintain, and control. Aircraft disposition, maintenance status, aircrew currency, and other key data are often tracked with felt tip pens on whiteboards or entered in excel spreadsheets. Whiteboards are stationary, cumbersome, and exposed. Spreadsheets are inaccessible, unstable, and vulnerable to the whims of information technology mishaps. Transposing data creates the potential for input error (read: fat fingering). Nevertheless, the existing system of analog whiteboards and spreadsheets is "tried and true." Therefore, our Aviation leaders trust them and are willing to endure these slow and inaccurate systems.

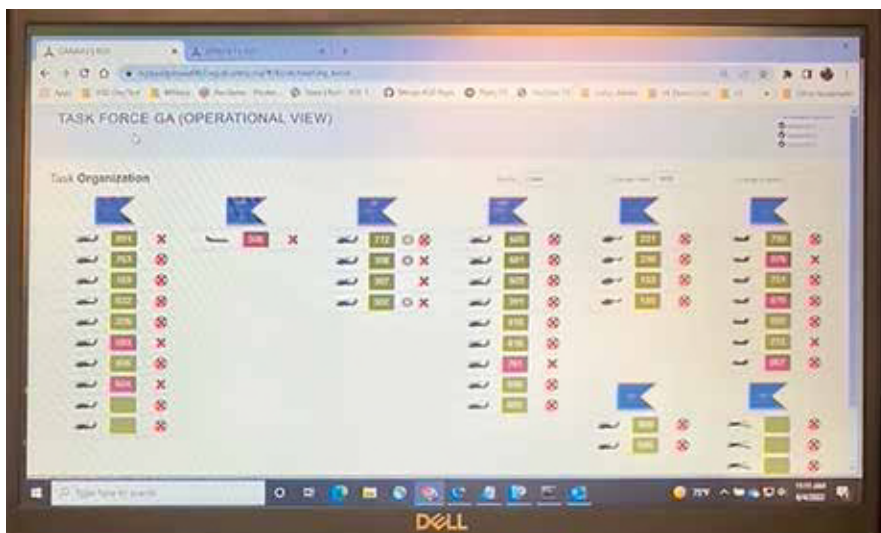

Dashboard Operational overview.

Tow Bridle Load Out Kits

US Army and Air Force Primary Load Out Kit

- Approved For All Army Helicopters
- Lightweight - High Strength
- Plasma® 12 Strand Ropes
- Carbon Fiber Spreader Bar
- Lines Maintain Equal Tension
- Required Class 9 Equipment

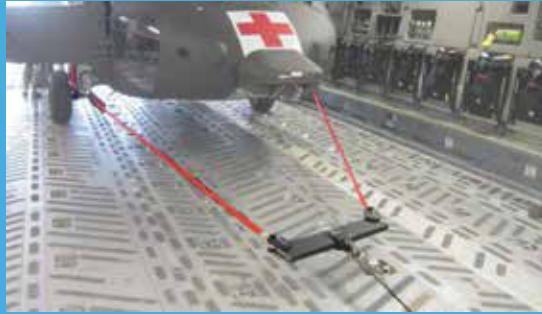

Call for more information (864) 638-6196 or
visit our website www.heli-basket.com.



The appearance of U.S. Department of Defense (DoD) visual information
does not imply or constitute DoD endorsement.

HELI BASKET™

RESCUE - DEPLOYMENT - LOGISTICS

For Your Most Critical Missions, Trust **HELIBASKET™**

The good news is there are modern, digital systems available to the Army Aviation community right now that overcome problems and provide a safe, secure, transparent means to manage data seamlessly and efficiently.

The Problem: *Corrupt data housed within legacy Army Systems are hard to identify and correct*

The Solution: *New technology makes it possible to improve data quality by illustrating information from multiple data sources and highlighting discrepancies*

With applications like the Aviation Status Dashboard (ASD) by Lulius Innovation, it's now possible to collate data such as aircraft status, crew readiness, and even additional flight training pay status currently residing in multiple, unconnected existing databases. Data from the Aircraft Notebook, the Centralized Aviation Flight Record System (CAFRS), the Integrated Personnel and Pay System – Army (IPPS-A), and many other sources, are brought together and integrated into one readable form, all in real time. The unique benefit of the ASD platform is that it can be quickly interfaced to nearly every other data source. This ability to fuse data into an easily understood organizational-level picture is a game-changer for Army Aviation. Having the ability to connect “source of truth” data from a multitude of previously unconnected sources puts platoon leaders, instructor pilots, production control, operations, and maintenance managers all on the same “sheet of music” and drastically improves the unit's ability to train and fight effectively. Having access to data without the need for human intervention improves overall situational awareness while reducing the risk of data entry errors. With innovative workflows and a modern platform like ASD, all data sets are presented to all users simultaneously enabling an easy transparent comparison of the data for improved accuracy.

The Problem: *No easy way to visualize aircraft and personnel status*

The Solution: *Use the power of data fusion technology available with modern information tools*

Despite efforts to store all data in the cloud, Army Aviation still relies on legacy distributed data systems and processes for everyday management activities. Local access to data is important, especially in contested environments or while operating within the limitations

of unreliable networks. Distributed data is beneficial because it provides Aviation leaders with the ability to manage data independently of the automation environment. Today, Aviation units use locally generated data created in the Aircraft Notebook and CAFRS programs which store aircraft maintenance and aircrew data, respectively. Historically, these data can only be accessed by administrators or users with special access permissions. This “lock-out” strategy severely inhibits a leader's ability to make critical decisions like resource allocation, operational readiness, and workforce efficiencies. Platforms like ASD provide direct visualization of aircraft and personnel status in a single “kiosk” view. These views provide all levels a better understanding of what's available for everything from routine training missions and maintenance management to domestic support operations like forest fires, hurricanes or emergency search and rescue missions. For the first time in Army Aviation history, new applications allow Aviation Brigade Commanders to see their entire brigade aircraft and aircrew status before a major exercise or a combat deployment all in one information system. Enabling Aviation commanders with real time, accurate readiness information will provide them with the ability to mission command with confidence and competence.

The Problem: *Complicated, antiquated management systems adversely affect readiness*

The Solution: *Develop, field, and continually improve Soldier-driven workflows*

Historically, digital systems have been developed for the Army through a process of top-driven requirements analysis followed by traditional acquisition program development and fielding that's slow, expensive, and ultimately doesn't meet the needs of the Soldiers who use the systems. This is one of the reasons “tried and true” analog processes still dominate the enterprise. New technology development methods are changing this paradigm. Applications are now being fielded that are 100 percent driven by the users' needs through unique, iterative, developmental processes. The result is improved systems that make workflows for Soldiers at the user-level friendly, efficient, and most importantly, they make their job easier. Reducing the time Soldiers spend fighting with slow, unproductive, frustrating information

tools so they spend more time on training and other more productive activities has a direct positive effect on retention and therefore readiness. Moreover, the easily understood information provided leads to improved command-wide communication structure and a better managed Aviation operation.

The Problem: *Relying on crew-estimated flight time*

The Solution: *Monitoring “on condition” time instead of “time on wing” or “hours flown”*

Flight time begins when an aircraft leaves the ground and ends when the power levers are turned off. Aviators record this span by hand, typically punching flight time estimates into their laptops based on their personal account of takeoff and shut down. While it may not seem significant, the 0.1 hours between an estimated 1.7 and actual 1.6 hours can make a significant difference when aggregated over the course of the life of the aircraft and for an entire fleet of aircraft. Airlines recognize the financial effect of precise timing and have implemented systems to accurately measure and record such data. Fortunately, with the Aviation Status Dashboard, Army Aviation units can similarly measure the time flown. The resulting improved accuracy results in substantial savings on scheduled maintenance. With a platform like ASD in the environment, and the future ability to record data accurately and make more accurate bank time planning, the cost of flying hours savings will be obvious.

As the Army Aviation fleet undergoes modernization, transitioning to information tools that improve operational management of both modern and legacy aircraft and crew is vital. Allowing small businesses an opportunity to innovate and assist Army leadership in accurately seeing itself in real-time will help move Army Aviation into the Information Age. Maybe then we can advance past the slow, inaccurate “tried and true” methods holding us back. Our Soldiers will thank us.

MG (Ret.) Tim Gowen was the Adjutant General for the Maryland National Guard and Senior Army Aviator; and COL (Ret.) Rich Ferguson, the former commander, 29th Expeditionary Combat Aviation Brigade, Maryland ARNG, at the time this was written.



CTG
A DIVISION OF BLUE RAVEN
SOLUTIONS



**SUPPLY CHAIN SOLUTIONS TO
KEEP FLEETS AND SYSTEMS
OPERATIONAL, READY AND SAFE**

CTG, a Division of Blue Raven Solutions, provides Government, Defense, and Commercial markets with tech-enabled, scalable supply chain solutions throughout platform lifecycles.



WE ARE YOUR FORCE MULTIPLIER

We dedicate the resources necessary to thoroughly understand your program at a level that allows us to become your force multiplier.



CERTIFIED & TRUSTED SUPPLIER

Our extensive Quality Assurance, Counterfeit Prevention Programs, and Cybersecurity Initiatives meet stringent military and aerospace requirements.



FLEXIBLE CONTRACTING OPTIONS

Move your program forward quickly by leveraging our rapid acquisition contracting options tailored to your specific requirement.

OUR TRUSTED SUPPLY CHAIN SOLUTIONS

- Hard-to-Find & Obsolete Parts
- DMSMS & Obsolescence Management
- Counterfeit Prevention Program
- Warehousing & Staging Optimization
- Custom Kitting
- Production Line Support

**WE SUPPORT MULTI-DOMAIN OPERATIONS
Air, Ground, Sea, Cyber & Space**



 1 Odell Plaza, Yonkers, NY 10701

 844-777-0057

 sales@ctgnow.com

► From the Field

The Army's AH-64 New Equipment Training Team (NETT)

By Mr. Ricky Denny and Mr. Tom Beck



The NETT, comprised of Team DigiFlight personnel, active-duty personnel, and Department of the Army civilians, plays a vital role in the comprehensive materiel development process of the AH-64 Apache helicopter. The Team's objective is to provide New Equipment Training (NET) for operators and maintainers of the AH-64, ensuring seamless operational integration of newly introduced software and hardware upgrades. This thorough training ensures that aviators and maintainers have the knowledge and skills to utilize and maintain the advanced AH-64 systems effectively. The qualifications obtained by aviators and maintainers under the guidance of the NETT ensure a skilled workforce capable of harnessing the full potential of the AH-64. To support its objective the NETT provides global fielding support, training for software and hardware upgrades, Program of Instruction (POI) and Training Support Plan (TSP) Development, and AH-64D to E Training and Readiness support.

Global Fielding Support

The NETT program actively contributes to the global fielding of the AH-64E aircraft with allied nations. The Team's worldwide reach with training and support enhances partner nation capabilities and strengthens international partnerships. The program extends its expertise and assistance to multiple countries, including the Netherlands, Qatar, United Kingdom, and the Kingdom of Saudi Arabia. Each allied country receives tailored training packages that align with nation-unique mission equipment requirements, enabling them to fully leverage the advanced features and functionalities of the AH64E aircraft. This includes training for PNVIS Image Intensification, HF

A DigiFlight SME provides AH-64 NET instruction.

Radio, Manned-Unmanned Teaming (MUMT), AH-64D V13.3, and AH-64E V6. Through their collective efforts, the NETT maintains its position as a cornerstone of the AH-64 Apache helicopter's development, ensuring its continuous advancement and the success of allied nations worldwide.

Training for Hardware and Software Upgrades

Since 2010, 18 special software and hardware upgrades have been implemented for the AH-64D and AH-64E aircraft, including advancements to the Modernized Target and Sight System and the Fire Control Radar. With each upgrade, the Team diligently prepares aviators and maintainers to effectively utilize and maintain these enhanced systems. The NETT is committed to facilitating the integration of other enhancements, such as the SPIKE missile, Common Infrared Countermeasure System (CIRCM), and Improved Turbine Engine Program (ITEP). By staying at the forefront of technological advancements and providing effective training, the PM Apache New Equipment Training Team is vital in ensuring the AH-64 Apache fleet remains a cutting-edge and capable asset for allied nations.

Program of Instruction (POI) and Training Support Plan (TSP) Development

The NETT plays a crucial role in training development, aligning its efforts with the Team's overarching training objectives and producing essential initial training materials. Working as an effective extension of the United States Army Aviation Center of Excellence (USAACE), the Team functions under a

DRIVEN.



At PCX Aerosystems, it comes as no surprise that we remain the foremost leader in main rotor, gearbox and power transmission systems for today's leading OEM's. We harness technology and engineering innovation to meet even the most challenging requirements. From a single gear to a fully tested assembly, we offer unmatched precision machining and overhaul and repair resources.

Now that's drive.



www.pcx aero.com

PM Apache written and TRADOC-approved POI. This POI is the backbone for the PM Apache AH-64E Aircraft Series Transition Course, providing the necessary training and guidelines for successful qualification. The NETT has authored six POIs in their training development endeavors. These POIs have undergone thorough scrutiny and have received approval from the USAACE, attesting to their quality and effectiveness.

Furthermore, the NETT has successfully developed Training Support Plans for various software and hardware upgrades, including V4 and V6 upgrades, AH-64E-to-AH-64D qualification, MTADS and FCR upgrades, and the initial training for the Advanced Precision Kill Weapon System. The NETT focus has expanded to include community-wide interests in developing the AH-64E V6 Maintenance Test Pilot and Operator Flight School XXI courses. NETT contributions not only facilitate a smooth transition of training responsibilities but also ensure that training materials remain current and effective in keeping up with the evolving demands of the AH-64 Apache platform.

AH-64D To “E” Transition Training and Readiness

The qualification of AH-64D aviators and maintainers to operate and maintain the AH-64E is a critical mission undertaken by the NETT. Since 2014, with the approval of the POI and validation of the training, TRADOC, through USAACE, has empowered the NETT to qualify AH-64E maintainers and operators. The Team’s efforts have been instrumental in supporting the fielding of the AH-64E to 14 US Army units and five allied countries. Notably, they have qualified 1,327 aviators and 148 Maintenance Test Pilots, ensuring capable and skilled employment of the AH-64E platform. Looking ahead, the Team remains committed to expanding its impact and expertise. There are plans to train at least seven more US Army units and five

other allied nations, further bolstering the global adoption of the AH-64E variant. Beyond qualification, the Team goes the extra mile to set units up for success. They provide Link 16 Unit Manager Training, equipping aviators with the necessary skills to effectively manage and utilize the advanced communication capabilities of the AH-64E. Additionally, Maintenance Test Pilot support is provided during the initial receipt of the aircraft, ensuring a smooth transition and optimal readiness of the units. Through their rigorous qualification process and comprehensive support services, the NETT plays a pivotal role in ensuring the proficiency and operational effectiveness of AH-64D aviators and maintainers transitioning to the AH-64E variant. Their efforts contribute to the success of individual units and enhance the overall capabilities of the AH-64 Apache fleet on a global scale.

Executing their multiple objectives of providing meticulous New Equipment Training, and seamlessly integrating software and hardware upgrades into the AH-64 Apache helicopter ensures aviators and maintainers have the knowledge and skills to utilize and maintain the advanced systems effectively. Their development of training to support overarching NET and institutional training objectives facilitates a seamless transition of training responsibilities. Finally, the Team’s active contribution to the global fielding of the AH-64E aircraft, extending support to provide exceptional allied nation warfighting capabilities. The NETT is well-positioned to continue supporting its core mission for the AH-64E V6.5 variant.

Mr. Ricky Denny is the Product Lead for International Aviation, U.S. Army Program Executive Office for Simulation, Training and Instrumentation (PEO STRI/IPO), Redstone Arsenal, AL and Mr. Tom Beck is a vice president at DigiFlight, Inc.

THE AGT IS NOW ON GSA

ALREADY AT...

- FT. NOVOSEL
- NET TEAM
- ARNG
- FMS
- CABs



avtsim.com | (407) 381-5311 | 4715 Data Court, Orlando FL 32817

Train Before Flight with the Apache Gunnery Trainer (AGT)®



Increase Proficiency from the Front Seat of the Apache

BE THE BEST ABOVE THE BEST WITH THE AGT

Available Modes

- Free Play -
- Switchology -
- Courseware -
- Single Station -
- Linked Station -
- Thumb Force -
- Controller -
- Engagement -
- Editor
- Trainee Records -



ROTORS or WINGS

WE'VE GOT YOU COVERED!

Refuel

Defuel

Mobilize

HELIFUELER[®]
ROTARY WING FUEL CART

HANDIFUELER
UAS FUEL SERVICE CART



Mission Engineered!

Equipped to fit all US Army Helicopters

Refuel/Defuel safely and easily

400 or 600 gallon double-walled tank

2-stage fuel filtration

CH-47 transportable (empty)

400 or 600 gallon double-walled tank

SPR refuel capability

Defuel for maintenance or deployment

Operates via onboard deep cycle batteries

Self-contained operation

www.SpokaneStainless.com

 **SPOKANE
STAINLESS
TECHNOLOGIES**



2023 National Functional Award Winners

Army Aviation Association of America

Army Aviation Association of America 2023 Aircraft Survivability Equipment Award

Sponsored by BAE Systems, Inc.



SPC Jacob A. Leath

Company D, 3rd Battalion,
160th Special Operations Aviation
Regiment (Airborne)
Hunter Army Airfield, Georgia

Specialist Jacob A. Leath is the example of maintenance experience, leadership, and professionalism; he has been the embodiment of a Night Stalker from the moment he first arrived at 3rd Battalion. Specialist Leath is a subject matter expert on Night Vision Goggles, Aviation Radios and Aircraft Survivability Systems and was an integral part of the implementation of the brand new Common Infrared Countermeasures system. Specialist Leath's maintenance experience in the shop has contributed to the superb upkeep of ASE installed on 16 MH-47G and 10 MH-60M helicopters with a value over one billion dollars. Specialist Leath has been an integral part of conducting maintenance on no notice deployment aircraft resulting in all ASE being Fully Mission Capable before departure. Specialist Leath consistently takes the initiative to complete any task, providing a glowing example for his peers and subordinates alike. His consistent dedication to the Night Stalker team and the mission has ensured that he, the unit, and the Soldiers he works with are ready to move at a moment's notice both physically and mentally. Specialist Leath's service to Army Aviation has been nothing short of exceptional and is why he is the only choice for the 2023 Army Aviation Association of America Aircraft Survivability Equipment Award.

Army Aviation Association of America CW3 Christopher M. Allgaier Aviation Mission Survivability Officer Award

Sponsored by Milltope Corporation



CW3 Joshua Palowitch

Headquarters and Headquarters
Company, 2nd Battalion,
160th Special Operations Aviation
Regiment (Airborne)
Fort Campbell, Kentucky

CW3 Josh Palowitch's contributions to the success of 2/160th Special Operations Aviation Regiment (SOAR) is directly related to his hard work and dedication to his craft, at home and deployed. In the most deployed unit in Army Aviation, Josh constantly must stay ahead of the threat that each new operating environment poses to ensure the safety of 16 MH-47G and 24 MQ-1C aircraft. Josh oversees the Battalion's ASE programs which ensured successful mission accomplishment executing innumerable targets over 10,000 hours flown in combat.

CW3 Palowitch is the first Unmanned Aircraft System warrant officer to both receive the AMSO identifier and hold an AMSO position with the 160th SOAR (Abn). His ability to plan, execute, and most importantly, teach aviators and UAS operators responsible for protecting our nation's most elite warriors is unmatched. Recently, CW3 Palowitch demonstrated, for the first time, the ability to protect a Helicopter Assault Force from anti-aircraft weapons by integrating MQ-1s into mission planning and execution. He oversaw the training and education of over 240 aviators and UAS operators while conducting 13 realistic training exercises throughout the United States over the past year. CW3 Palowitch's tactical and technical expertise, intrinsic motivation, and his ability to develop challenging and realistic training are why he is the 2023 AAAA Christopher M. Allgaier Aviation Mission Survivability Officer Award winner.

Army Aviation Association of America 2023 Avionics Award

Sponsored by Cubic DefenseSystems, Inc.

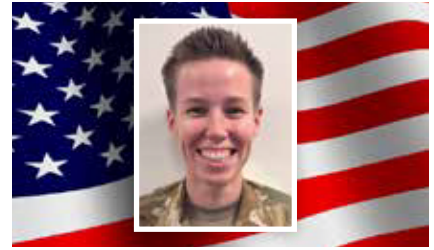

SGT Shelby M. Hinkens

Company D, 2nd Battalion, 158th Aviation
Regiment,
16th Combat Aviation Brigade
Joint Base Lewis-McChord, WA

Sergeant (SGT) Shelby Hinkens epitomizes what it means to be a consummate professional and technical expert in her field. Through her selfless dedication and demonstrated performance, it is evident that she has made vast individual contributions to Army Aviation as a maintainer and leader. SGT Hinkens has accumulated over 1500 maintenance hours and has participated in many Joint Multi-National Operations across multiple theaters.

She currently serves as the Delta Company Avionics Maintenance NCO, where she is responsible for the maintenance output and personnel allocation of the entire shop. Under her direction, the Battalion's Fully Mission Capable (FMC) rate has increased over the last two quarters. This is especially significant considering the 2-158th Assault Helicopter Battalion has one of the most aggressive Flying Hours Program (FHP) of any Assault Helicopter Battalion in the United States Army.

SGT Hinkens is a phenomenal maintainer, a well-rounded and transformational leader, one who always leads by example. It is through her character, work ethic, and individual contributions to Army Aviation as a junior leader that she demonstrates unwavering potential to lead; and embodies everything the AAAA Avionics Award represents.

Armed and Tested

Advancing Armament System Operational Readiness & Performance



Hellfire Scalable Rail Launcher (HSRL)

The Next Evolution of the Hellfire Launcher

- Scalable design and multiple configurations
- Innovative lightweight, DC-only Hellfire launchers
- Distributed architecture to support FARA and FLARA requirements



Advanced Armament Test Solutions

- Rugged, lightweight, handheld, easy to use
- Reduced logistics, training and manpower footprint
- Field (AVUM/AVMC) and Intermediate (AVIM/ASB) Levels



MARVINTEST.COM



ARMY AVIATION

2023 Blue Book Directory

Thanks to the hundreds of units and offices that responded to this year’s request for information and to each activity listed. This directory of Army aviation units, organizations, offices and key personnel includes information from both the Active and Reserve components, principally at the battalion level and above, and by key supporting organizations. All information is presented in alphabetical state order by city and installations, then by U.S. territories, followed by overseas regions and countries.

Organizations that did not provide input in 2023 or who did not follow published requirements are noted as “*Update Not Provided This Year.” Additionally, for units and organizations that have not updated their data since 2019, key personnel names, personal email listings and photos may have been deleted due to likelihood of personnel turnover.

For future updates, instructions and forms are available throughout the year on the website homepage under the “Magazine” tab, on the drop down menu. Please contact bluebook@quad-a.org or call (203) 268-2450 with any questions. *Joe Pisano/Editor*

I Corps	105	59th Avn. Troop Cmd.	98	1st Bn., 211th Avn. Regt.	102
III Corps, G3 Air	100	78th Avn. Troop Cmd.	81	1st Bn., 212th Avn. Regt.	60
XVIII Airborne Corps	94	96th Avn. Troop Cmd.	105	1st Bn., 214th GSAB	108
XVIII Airborne Corps G3 Aviation Office	94	97th Avn. Troop Cmd.	102	1st Bn., 222nd Avn. Regt.	104
1st Cav. Div.	100	98th Avn. Troop Cmd.	72	1st Bn., 223rd Avn. Regt.	60
1st Cav. Div. G3 Aviation	100	772nd Avn. Troop Cmd.	106	1st Bn., 224th Avn. Regt.	88
2nd Inf. Div.	108	164th Theater Airfield Operations Group (TAOG)	62	1st Bn., 227th Avn. Regt.	101
4th Inf. Div., G3 Air	77	204th Theater Airfield Operations Group (TAOG)	87	1st Bn., 228th Avn. Regt.	107
7th Inf. Div.	105	1st Theater Sustainment Command	86	1st Bn., 229th Avn. Regt.	105
10th Mountain Div.	92	1100th Theater Avn. Sustain. Maint. Gp. (TASMG)	88	1st Bn., 230th Avn. Regt.	99
11th Abn. Div.	72	1106th Theater Avn. Sustain. Maint. Gp. (TASMG)	76	1st Bn., 244th Avn. Regt.	87
25th Inf. Div.	82	1107th Theater Avn. Sustain. Maint. Gp. (TASMG)	91	1st Bn., 376th Avn. Regt.	91
28th Inf. Div.	97	1108th Theater Avn. Sustain. Maint. Gp. (TASMG)	90	1st Bn., 501st Avn. Regt.	100
35th Inf. Div.	83	1109th Theater Avn. Sustain. Maint. Gp. (TASMG)	77	2nd Bn., 1st Avn. Regt.	84
36th Inf. Div.	99	1st Multi-Domain Task Force	105	2nd Bn., 2nd Avn. Regt.	108
38th Inf. Div.	83	1st Bn., 1st Avn. Regt.	84	2nd Bn., 3rd Avn. Regt.	80
42nd Inf. Div.	94	1st Bn., 3rd Avn. Regt.	108	2nd Bn., 4th Avn. Regt.	77
81st Readiness Div.	98	1st Bn., 10th Avn. Regt.	93	2nd Bn., 10th Avn. Regt.	93
82nd Abn. Div.	94	1st Bn., 11th Avn. Regt.	60	2nd Bn., 25th Avn. Regt.	82
101st Airborne Division	84	1st Bn., 13th Avn. Regt.	58	2nd Bn., 82nd Avn. Regt.	94
1st Air Cav. Bde.	101	1st Bn., 14th Avn. Regt.	60	2nd Bn., 104th Avn. Regt.	97
1st Avn. Bde.	58	1st Bn., 25th Avn. Regt.	72	2nd Bn., 111th Avn. Regt.	80
1st AD, Cbt. Avn. Bde.	99	1st Bn., 52nd Avn. Regt.	70	2nd Bn., 130th Avn. Regt.	95
1st AD, Cbt. Avn. Bde.	83	1st Bn., 58th Avn. Regt.	62	2nd Bn., 135th Avn. Regt.	77
2nd Cbt. Avn. Bde.	108	1st Bn., 82nd Avn. Regt.	94	2nd Bn., 149th Avn. Regt.	102
3rd Cbt. Avn. Bde.	80	1st Bn., 101st Avn. Regt.	84	2nd Bn., 151st Avn. Regt.	98
4th Cbt. Avn. Bde.	77	1st Bn., 106th Avn. Regt.	83	2nd Bn., 147th Avn. Regt.	89
10th Cbt. Avn. Bde.	92	1st Bn., 107th Avn. Regt.	99	2nd Bn., 149th Avn. Regt.	102
11th Exp. Cbt. Avn. Bde.	77	1st Bn., 108th Avn. Regt.	84	2nd Bn., 158th Avn. Regt.	105
12th Cbt. Avn. Bde.	107	1st Bn., 111th Avn. Regt.	79	2nd Bn., 160th Special Ops. Avn. Regt.	85
16th Cbt. Avn. Bde.	105	1st Bn., 114th Avn. Regt.	74	2nd Bn., 185th Avn. Regt.	90
25th Cbt. Avn. Bde.	92	1st Bn., 126th Avn. Regt.	98	2nd Bn., 210th Avn. Regt.	104
28th Exp. Cbt. Avn. Bde.	83	1st Bn., 130th Avn. Regt.	95	2nd Bn., 211th Avn. Regt.	102
29th Cbt. Avn. Bde.	82	1st Bn., 131st Avn. Regt.	62	2nd Bn., 224th Avn. Regt.	104
34th Exp. Cbt. Avn. Bde.	89	1st Bn., 135th Avn. Regt.	91	2nd Bn., 227th Avn. Regt.	101
35th Exp. Cbt. Avn. Bde.	91	1st Bn., 137th Avn. Regt.	96	2nd Bn., 228th Avn. Regt.	92
36th Cbt. Avn. Bde.	99	1st Bn., 140th Avn. Regt.	76	2nd Bn., 238th Avn. Regt.	83
38th Cbt. Avn. Bde.	83	1st Bn., 145th Avn. Regt.	58	2nd Bn., 245th Avn. Regt.	96
40th Cbt. Avn. Bde.	74	1st Bn., 147th Avn. Regt.	106	2nd Bn., 285th Avn. Regt.	74
42nd Cbt. Avn. Bde.	93	1st Bn., 149th Avn. Regt.	102	2nd Bn., 291st Avn. Regt.	100
63rd Theater Avn. Bde.	86	1st Bn., 150th Avn. Regt.	92	2nd Bn., 501st Avn. Regt.	100
77th Theater Avn. Bde.	74	1st Bn., 151st Avn. Regt.	98	2nd Bn., 641st Avn. Regt.	96
82nd Cbt. Avn. Bde.	94	1st Bn., 158th Avn. Regt.	99	3rd Bn., 1st Avn. Regt.	84
101st Cbt. Avn. Bde.	84	1st Bn., 160th Special Ops. Avn. Regt.	85	3rd Bn., 2nd Avn. Regt.	108
110th Avn. Bde.	60	1st Bn., 168th Avn. Regt.	105	3rd Bn., 4th Avn. Regt.	77
110th Avn. Bde. (Aug.)	60	1st Bn., 169th Avn. Regt.	78	3rd Bn., 10th Avn. Regt.	93
128th Avn. Bde.	104	1st Bn., 171st Avn. Regt.	81	3rd Bn., 58th Avn. Regt.	95
160th Special Operations Avn. Regt.	85	1st Bn., 183rd Avn. Regt.	82	3rd Bn., 82nd Avn. Regt.	94
166th Avn. Bde.	100	1st Bn., 185th Avn. Regt.	90	3rd Bn., 126th Avn. Regt.	89
185th Exp. Cbt. Avn. Bde.	90	1st Bn., 189th Avn. Regt.	91	3rd Bn., 140th Avn. Regt.	76
244th Exp. Cbt. Avn. Bde.	97	1st Bn., 207th Avn. Regt.	72	3rd Bn., 142nd Avn. Regt.	93
449th Cbt. Avn. Bde.	95	1st Bn., 210th Avn. Regt.	104	3rd Bn., 160th Special Ops. Avn. Regt.	80
The Army Avn. Bde. (TAAB)	103			3rd Bn., 227th Avn. Regt.	101
				3rd Bn., 238th Avn. Regt.	89
				3rd Bn., 25th Avn. Regt.	82

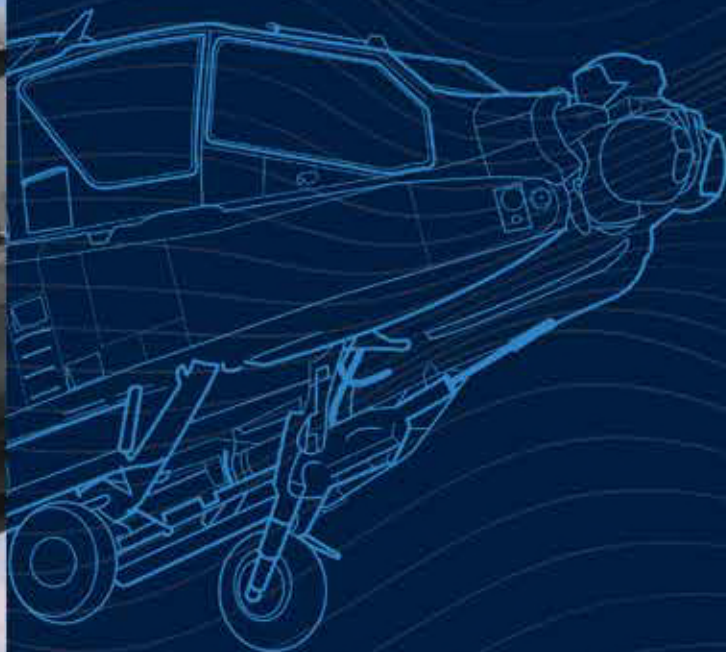

amentum >

Solving what's next.™

Next generation maintenance.

Leveraging artificial intelligence to predict with speed and decide with accuracy.

Next generation people.

Training Army Aviation's future generations to meet the unpredictable.



amentum.com

3rd Bn., 351st Avn. Regt.....	100
3rd Bn., 501st Avn. Regt.....	100
4th Bn., 2nd Avn. Regt.....	108
4th Bn., 3rd Avn. Regt.....	80
4th Bn., 4th Avn. Regt.....	77
4th Bn., 58th Avn. Regt.....	109
4th Bn., 160th Special Ops. Avn. Regt.....	105
5th Bn., 101st Avn. Regt.....	84
5th Bn., 159th Avn. Regt.....	104
6th Bn., 52nd Avn. Regt.....	76
6th Bn., 101st Avn. Regt.....	84
7th Bn., 158th Avn. Regt.....	101
8th Bn., 229th Avn. Regt.....	85
5th Avn. Bn., JRTC.....	86
12th Avn. Bn.....	103
2916th Avn. Bn. (NTC).....	74
Spec. Ops. Avn. Tng. Bn. (SOATB).....	85
U.S. Army Aviation Battalion, Japan.....	108
1st Sqdn., 6th Cav. Regt.....	84
1st Sqdn., 17th Cav. Regt.....	94
2nd Sqdn., 6th Cav. Regt.....	82
2nd Sqdn., 17th Cav. Regt.....	85
3rd Sqdn., 6th Cav. Regt.....	100
3rd Sqdn., 17th Cav. Regt.....	80
4th Sqdn., 6th Cav. Regt.....	105
4th Sqdn., 17th Cav. Regt.....	109
5th Sqdn., 6th Cav. Regt.....	93
6th Sqdn., 17th Cav. Regt.....	77
7th Sqdn., 17th Cav. Regt.....	101
302nd Sqdn. Royal Netherlands Air Force.....	100
46th Avn. Spt. Bn.....	105
90th Avn. Spt. Bn.....	101
96th Avn. Spt. Bn.....	85
122nd Avn. Spt. Bn.....	94
127th Avn. Spt. Bn.....	100
209th Avn. Spt. Bn.....	82
248th Avn. Spt. Bn.....	87
277th Avn. Spt. Bn.....	93
351st Avn. Spt. Bn.....	98
404th Avn. Spt. Bn.....	77
449th Avn. Spt. Bn.....	102
601st Avn. Spt. Bn.....	84
602nd Avn. Spt. Bn.....	109
603rd Avn. Spt. Bn.....	80
615th Avn. Spt. Bn.....	101
628th Avn. Spt. Bn.....	97
638th Avn. Spt. Bn.....	83
640th Avn. Spt. Bn.....	76
642nd Avn. Spt. Bn.....	93
777th Avn. Spt. Bn.....	74
834th Avn. Spt. Bn.....	89
935th Avn. Spt. Bn.....	91
1204th Avn. Spt. Bn.....	84
3rd Mil. Intel. Bn. (Aerial Exploitation).....	109
15th Mil. Intel. Bn. (Aerial Exploitation).....	101
116th MI Bde., (Aerial Intelligence).....	80
116th Processing, Exploitation Dissemination (PED) Bn. (Aerial Exploitation).....	80
204th Mil. Intel. Bn. (Aerial Reconnaissance).....	100
206th Mil. Intel. Bn. (Aerial Exploitation).....	101
224th Mil. Intel. Bn. (Aerial Exploitation).....	81
304th Mil. Intel. Bn.....	72
U.S. Army Air Ambulance Detachment (USAAD), Fort Novosel (FLATIRON).....	60
U.S. Army Air Ambulance Detachment (USAAD), 214th Med. Det.....	107
U.S. Army Air Ambulance Detachment, Fort Johnson.....	87
1st Battlefield Coordination Detachment, USARSO.....	72
5th Battlefield Coord. Det.....	82
Det. 1, Co. C, 3rd Bn., 140th Avn. Regt.....	96
Det. 6, Opn. Spt. Airlift Agency (OSA-A).....	78
Det. 12, Opn. Spt. Airlift Agency (OSA-A).....	89
Det. 15, Opn. Spt. Airlift Agency (OSA-A).....	89
Det. 17, Opn. Spt. Airlift Agency (OSA-A).....	95
Det. 19, Opn. Spt. Airlift Agency (OSA-A).....	92
Det. 28, Opn. Spt. Airlift Agency (OSA-A).....	87
Det. 55, Opn. Spt. Airlift Agency (OSA-A).....	82

Air Warrior Product Office.....	64
Aircraft Survivability Equipment Project Management Office (PM ASE).....	62
Airfield Division, Davison Army Airfield/Pentagon Helipad 103.....	95
Airfield Division, DPTM.....	95
Airfield Operations Branch, G-3/5/7.....	102
Alabama ARNG Aviation Support Facility #1.....	62
Alabama ARNG Aviation Support Facility #2.....	56
Alabama ARNG Aviation Support Facility #3.....	64
Alaska ARNG Aviation Operating Facility #1.....	72
Alaska ARNG Aviation Operating Facility #2.....	70
Alaska ARNG Aviation Operating Facility #3.....	72
Alaska ARNG Aviation Operating Facility #4.....	72
Alaska ARNG Aviation Support Facility.....	70
AMCOM G-3/5.....	64
AMCOM Logistics Center (ALC).....	64
AOA-E East.....	108
Apache Attack Helicopter Project Office.....	66
Arizona ARNG Aviation Support Facility #1.....	74
Arizona ARNG Aviation Support Facility #2.....	72
Arkansas ARNG Aviation Support Facility.....	74
Army Air Div., WSMR.....	92
Army Aviation Directorate, HQDA DCS G-3/5/7.....	78
Army Aviation Division, Force Development, DCS G-8.....	79
Army Aviation Flight Activity Fresno.....	76
Army Aviation Support Facility #1.....	106
Army Aviation Support Facility #2.....	105
Army Capability Manager, Lift (ACM-Lift).....	58
Army Capability Manager, Reconnaissance and Attack (ACM-RA).....	58
Army Contracting Command-Redstone (ACC-RSA).....	70
Army National Guard.....	103
Army Reprogramming Analysis Team-Program Office (ARAT-PO).....	88
ARNG Austin Army Aviation Support Facility #1.....	99
Assistant Secretary of the Army for Acquisition, Logistics & Technology (ASAALT).....	78
Aviation & Electronics Branch, G4, FORSCOM.....	94
Aviation and Fires Evaluation Directorate (AFED), Army Evaluation Center.....	87
Aviation and Safety Division, Army National Guard.....	103
Aviation Branch Historian.....	56
Aviation Branch Safety Office.....	56
Aviation Branch, OPMD, U.S. Army Human Resources Command.....	86
Aviation Capability Development and Integration Directorate (ACDID).....	58
Aviation Center Logistics Command (AACL), AMCOM.....	62
Aviation Company, Task Force Sinai, Multinational Force & Observers (MFO).....	107
Aviation Directorate (USARC).....	95
Aviation Div., Training and Leader Development.....	104
Aviation Division Operations Group, JRTC.....	86
Aviation Division, Dep. Ch. of Staff, Log., G-4.....	79
Aviation Division, DPTMS, Waynesville-St. Robert Regional Airport at Forney Field.....	90
Aviation Division, Felker Army Afd.....	104
Aviation Division, G-1 Safety.....	64
Aviation Division, G-3/5/7, FORSCOM.....	94
Aviation Division, Joint Base Lewis-McChord.....	106
Aviation Enablers Requirements Determination Directorate (AE-RDD).....	58
Aviation Enlisted Management Branch, EPMD.....	86
Aviation Field Maintenance Directorate (AFMD).....	64
Aviation Logistics Branch, 21st Theater Sustainment Command.....	107
Aviation Maintenance Directorate (ARSOAC).....	85
Aviation Mission Systems & Architecture Project Office (AMSA).....	70
Aviation Office, Eighth U.S. Army.....	108
Aviation Platforms - Requirements Determination Directorate (AP-RDD).....	58
Aviation Safety Support Center ARNG.....	62
Aviation Support Facility.....	77
Aviation Support Facility - ASF Conroe 1/158 HSB.....	102
Aviation Support Facility - Eustis.....	104
Aviation Support Facility - Hood.....	101
Aviation Support Facility - Lewis.....	106
Aviation Support Facility - Los Alamitos.....	76
Aviation Support Facility - Olathe.....	84
Aviation Support Facility (ASF) - Novosel.....	62
Aviation Technical Assistance Fielding Team.....	107
Aviation Test Directorate, USAOTC.....	101
Aviation Turbine Engines Project Office (ATE).....	68

Aviation Warrant Officer Assignments Branch.....	86
Avn. Det., CBRNE Analytical & Remediation Activity.....	88
Avn. Test Dir., Plan and OPS Division.....	101
Biggs Army Airfield.....	100
California ARNG Aviation Support Facility #1.....	76
California ARNG Aviation Support Facility #2.....	76
California ARNG Aviation Support Facility #3.....	76
Cargo Helicopter Project Office.....	68
Cargo Helicopters - Multi-National Aviation Special Project Office (PM CH-MASPO).....	64
Chief of Army Reserve (OCAR).....	78
Chief of Staff, U. S. Army.....	78
Combined Joint Task Force-Horn of Africa (CJTF-HOA).....	107
Commanding General, District of Columbia National Guard79	79
Concepts, Experimentation, and Analysis Directorate (CEAD).....	58
Connecticut ARNG Aviation Support Facility.....	78
Corpus Christi Army Depot (CCAD).....	99
Defense Contract Management Agency (DCMA).....	104
Defense Contract Management Agency (DCMA) Sikorsky Aircraft.....	77
Defense Contract Management Agency (DCMA), Boeing - Philadelphia.....	97
Defense Contract Management Agency, Bell Helicopter Textron.....	101
Defense Contract Management Agency, Boeing - Mesa.....	72
Defense Logistics Agency - Aviation.....	104
Defense Logistics Agency - Land & Maritime (DLA L&A).....	96
Deputy Chief of Staff, G-4.....	79
Deputy Chief of Staff, G-8.....	79
Deputy Chief of Staff, Safety & Aviation, Virgin Islands ARNG.....	107
DEVCOM Aviation and Missile Center (AvMC).....	66
DEVCOM Command, Control, Computers, Comms., Cyber, Intel., Surv., & Recon. Center (DEVCOM C5ISRC).....	87
Director, Operational Test and Evaluation.....	78
Directorate for Aviation Munitions, DCS G-4.....	79
Directorate of Evaluation and Standardization (DES).....	58
Directorate of Plans, Training, Mobilization & Security, USAG Fort Novosel.....	56
Directorate of Simulation (DOS).....	58
Directorate of Training and Doctrine (DOTD).....	58
District of Columbia ARNG Army Aviation Support Facility.....	103
Eastern Army National Guard Aviation Training Site (EAATS).....	97
Embry-Riddle Aeronautical University Army ROTC.....	79
FAA DAR HQ.....	79
FAA DAR, Eastern Service Area.....	80
FAA DAR, Western Service Area.....	105
First Army Division West.....	100
Fixed Wing ARNG Aviation Training Site (FWAATS).....	106
Florida ARNG Aviation Support Facility #1.....	79
Florida ARNG Aviation Support Facility #2.....	79
Future Attack Reconnaissance Aircraft Project Office (FARA).....	68
Future Long Range Assault Aircraft Project Office (FLRAA).....	64
Future Vertical Lift Cross-Functional Team (FVL CFT).....	68
Georgia ARNG Aviation Support Facility #1.....	81
Georgia ARNG Aviation Support Facility #2.....	81
Georgia ARNG Aviation Support Facility #3.....	81
Hawaii ARNG Aviation Support Facility.....	82
Hawaii ARNG Aviation Support Facility #1.....	82
Hawaii ARNG Aviation Support Facility #2.....	81
Henry Post Army Airfield, Airfield Ops. Div, DPTMS.....	96
High Altitude ARNG Aviation Training Site (HAATS).....	77
Houston Army Aviation Support Facility (HAASF).....	102
Hunter Army Airfield Division.....	81
Idaho ARNG Aviation Support Facility.....	82
Illinois ARNG Aviation Support Facility #1.....	82
Illinois ARNG Aviation Support Facility #2.....	82
Illinois ARNG Aviation Support Facility #3.....	83
Incentives and Compensation Branch (ICB), SPSD/TAGD.....	86
Indiana ARNG Aviation Support Facility.....	83
Integrated Logistics Support Center (ILSC), CECOM.....	88
Iowa ARNG Army Aviation Support Facility #3.....	83
Iowa ARNG Aviation Support Facility #1.....	83



START LIGHTER
START FASTER
START SMARTER



Certified **Lithium-ion** Aircraft Batteries

Cut aircraft battery weight and increase your useful load. Like you, True Blue Power® batteries are always mission ready. They fully recharge within 30 minutes and deliver superior performance in the most rugged environments. Even better, you'll eliminate expensive battery maintenance and the need for ground power units. **Start LIGHTER, start FASTER and start SMARTER every time.**



truebluepowerusa.com/GETSTARTED

TRUE BLUE POWER®
A division of Mid-Continent Instrument Co., Inc.



SAVING LIVES SINCE 1981



SCAN ME

STILL OUR BEST SELLING PRODUCT
SKED CONTINUES TO SAVE LIVES



SKEDCO® PJ SKED
**(SK-215C) "LIGHTER
 FASTER
 EASIER TO CARRY"**

**UNIVERSAL LITTER
 TIE-DOWN STRAPS™**
NSN: 6530-01-530-3860

PATIENT LITTER STRAPS
NSN: 6530-01-536-4145





**The only Litter Tie-Down Strap
 with Airworthiness Release
 (AWR 1330), 3000lb MBS.
 Patient Litter Strap, 5000lb.**

WWW.SKEDCO.COM
800-770-7533



Iowa ARNG Aviation Support Facility #2	83
Joint Aircraft Survivability Program Office (JASPO)	103
Joint Multi-national Readiness Center-Hohenfels (JMRC) Aviation Detachment	108
Joint Program Executive Office, Armaments and Ammunition (PEO A&A)	92
Joint Readiness Training Center (JRTC)	86
Kansas ARNG Aviation Support Facility #1	84
Kansas ARNG Aviation Support Facility #2	84
Kentucky ARNG Aviation Support Facility #1	86
Letterkenny Army Depot	97
Los Alamitos Army Airfield	76
Louisiana ARNG Aviation Support Facility #1	87
Louisiana ARNG Aviation Support Facility #2	87
Lyster Army Health Clinic (LAHC)	60
Maine ARNG Aviation Support Facility	87
Maryland ARNG Aviation Support Facility	88
Massachusetts ARNG Aviation Support Facility #1	89
Massachusetts ARNG Aviation Support Facility #2	89
Michigan ARNG Aviation Support Facility #1	89
Michigan ARNG Aviation Support Facility #2	89
Military Deputy/Director, Army Acquisition Corps, OASA(ALT).	78
Military Intelligence Detachment (JSTARS)	81
Minnesota ARNG Aviation Support Facility #1	90
Minnesota ARNG Aviation Support Facility #2	89
Mississippi ARNG Aviation Support Facility #1	90
Mississippi ARNG Aviation Support Facility #2	90
Mississippi ARNG Aviation Support Facility #3	90
Mississippi Aviation Classification Repair Activity Depot (MS- AVCRAD)	90
Missouri Army Aviation Support Facility #1	91
Missouri ARNG Army Aviation Flight Facility	91
Missouri ARNG Aviation Support Facility #2	90
Missouri Aviation Classification Repair Activity Depot (MO- AVCRAD)	91
Modernization Division, Aviation Directorate	79
Montana ARNG Aviation Support Facility	91
NASA Detachment, Space and Missile Defense Command....	102
National Geospatial Intelligence Agency (NGA), Safety of Navigation	90
National Guard Bureau (NGB)	78
National Training Center (NTC)	74
Nebraska ARNG Aviation Support Facility #1	91
Nebraska ARNG Aviation Support Facility #2	91
Nevada ARNG Aviation Support Facility	92
New Hampshire ARNG Aviation Support Facility	92
New Jersey ARNG Aviation Support Facility	92
New Jersey ARNG Aviation Support Facility #1	92
New Mexico ARNG Aviation Support Facility	92
New York ARNG Aviation Support Facility #1	93
New York ARNG Aviation Support Facility #2	93
New York ARNG Aviation Support Facility #3	93
Noncommissioned Officer Academy, Fort Novosel	60
Noncommissioned Officer Academy-Eustis	104
North Carolina ARNG Aviation Support Facility #1	95
North Carolina ARNG Aviation Support Facility #2	95
North Dakota ARNG Aviation Support Facility	96
Office of Congressional Legislative Liaison (OCLL)	78
Office of the Secretary of Defense	78
Office of the Staff Judge Advocate	56
Ohio ARNG Aviation Support Facility #1	96
Ohio ARNG Aviation Support Facility #2	96
Oklahoma ARNG Aviation Support Facility #1	96
Oklahoma ARNG Aviation Support Facility #2	96
Operational Support Airlift Activity (OSA-A)	103
Operations and Readiness Division, Aviation Directorate ..	79
Operations Group, Aviation Task Force Training Team (Eagle Team)	74
Oregon ARNG Aviation Support Facility #1	96
Oregon ARNG Aviation Support Facility #2	96
Organization & Personnel Force Development Directorate (OPFD)	58
Pennsylvania ARNG Aviation Support Facility #1	97
Pennsylvania ARNG Aviation Support Facility #2	97
Program Executive Office, Aviation	66

Program Executive Office, Command, Control and Communi- cations (Tactical)(PEO C3T)	88
Program Executive Office, Intelligence, Electronic Warfare & Sensors (PEO IEW&S)	88
Program Executive Office, Missiles & Space	70
Program Executive Office, Simulation, Training & Instrumenta- tion (PEO STRI)	80
Project Manager, Terrestrial Sensors (formerly Night Vision/ RSTA)	103
Puerto Rico ARNG Aviation Support Facility	107
Ray S. Miller Army Airfield, Minnesota ARNG	89
Redstone Test Center (RTC)	66
Research and Technology Integration Directorate (RTI)	88
Rhode Island ARNG Aviation Support Facility	98
San Antonio Army Aviation Support Facility #2	102
Saudi Arabian National Guard Modernization Program	78
Secretary of the Army	103
Senior Leader Development (SLD) Colonels Management Office (COMO)	103
Sensors-Aerial Intelligence Project Office (PD S-AI / formerly PM ARES)	88
Software, Simulation, Systems Engineering and Integration (S3I) Directorate (DEVCOM AvMC)	66
South Carolina ARNG Aviation Support Facility #1	98
South Carolina ARNG Aviation Support Facility #2	98
Special Operations Directorate, U.S. Army Avn. and Missile Life Cycle Mgmt. Cmd (AMCOM)	104
Special Operations Forces Acquisition, Technology, and Logistics - Rotary Wing	80
Special Operations Joint Task Force-Levant	108
State Adjutants General	64
Alabama National Guard	70
Alaska National Guard	72
Arizona National Guard	74
Arkansas National Guard	76
California National Guard	77
Colorado National Guard	77
Connecticut National Guard	78
Delaware National Guard	80
Florida National Guard	81
Georgia National Guard	106
Hawaii National Guard	81
Idaho National Guard	82
Illinois National Guard	83
Indiana National Guard	83
Iowa National Guard	83
Kansas National Guard	84
Kentucky National Guard	86
Louisiana National Guard	87
Maine National Guard	87
Maryland National Guard	88
Massachusetts National Guard	89
Michigan National Guard	89
Minnesota National Guard	89
Mississippi National Guard	90
Missouri National Guard	90
Montana National Guard	91
Nebraska National Guard	91
Nevada National Guard	91
New Hampshire National Guard	92
New Jersey National Guard	92
New Mexico National Guard	92
New York National Guard	93
North Carolina National Guard	95
North Dakota National Guard	96
Ohio National Guard	96
Oklahoma National Guard	96
Oregon National Guard	96
Pennsylvania National Guard	96
Puerto Rico National Guard	107
Rhode Island National Guard	97
South Carolina National Guard	98
South Dakota National Guard	98
Tennessee National Guard	99
Texas National Guard	99
Utah National Guard	102
Vermont National Guard	102
Virgin Islands National Guard	107
Virginia National Guard	104
Washington National Guard	106

STRONG LEGACY. RELENTLESS INNOVATION.

Advanced solutions for Army Aviation.

Purpose built solutions to help the U.S. Army deploy
a more resilient, secure, and sustainable future.

THE
FUTURE
IS
WHAT
WE
MAKE IT

Honeywell



West Virginia National Guard.....	106	Oklahoma ARNG	96	U.S. Army Aviation and Missile Command (AMCOM).....	64
Wisconsin National Guard.....	106	Oregon ARNG	96	U.S. Army Aviation Center of Excellence (USAACE).....	56
Wyoming National Guard.....	106	Pennsylvania ARNG	97	U.S. Army Aviation Museum	58
State Army Aviation Officers.....		Puerto Rico ARNG	107	U.S. Army Cadet Command	85
Alabama ARNG	64	Rhode Island ARNG.....	98	U.S. Army C-E LCMC Software Engineering Center (SEC).....	88
Alaska ARNG.....	72	South Carolina ARNG.....	98	U.S. Army Center for Initial Military Training.....	104
Arizona ARNG.....	72	South Dakota.....	98	U.S. Army Central Command (USARCEN) G-32 Aviation ..	98
Arkansas ARNG.....	74	Tennessee ARNG.....	99	U.S. Army Combat Capabilities Development Command (DEVCOM).....	87
California ARNG.....	76	Texas ARNG.....	99	U.S. Army Combat Readiness Center.....	60
Colorado ARNG.....	76	Utah ARNG.....	102	U.S. Army Combined Arms Center.....	83
Connecticut ARNG.....	78	Vermont ARNG.....	103	U.S. Army Communications Electronics Command (CECOM).....	88
Delaware ARNG.....	78	Virginia ARNG.....	104	U.S. Army Contracting Command.....	70
District of Columbia ARNG.....	103	Washington ARNG.....	105	U.S. Army DEVCOM C51SR CENTER.....	92
Florida ARNG.....	80	West Virginia ARNG.....	106	U.S. Army Europe, G-3, Aviation Division.....	107
Georgia ARNG.....	81	Wisconsin ARNG.....	106	U.S. Army Europe, G-4, Aviation Office.....	107
Guam ARNG.....	106	Wyoming ARNG.....	106	U.S. Army Evaluation Center (USAEC).....	87
Hawaii ARNG.....	82	Systems Integration and Management Office (SIMO).....	85	U.S. Army Fixed Wing Project Office.....	68
Idaho ARNG.....	82	Systems Readiness Directorate (SRD)(DEVCOM AvMC).....	66	U.S. Army Flight Operations Detachment (AFOD).....	107
Illinois ARNG.....	83	Tactical Aviation and Ground Munitions (TAGM) Project Office.....		U.S. Army Flight Tng. Det. - Peace Vanguard.....	72
Indiana ARNG.....	83	Technology Applications Program Office (TAPO).....	104	U.S. Army Forces Command (FORSCOM).....	94
Iowa ARNG.....	83	Technology Development Directorate (TDD) (DEVCOM AvMC).....	66	U.S. Army Futures Command (AFC).....	99
Kansas ARNG.....	84	Tennessee ARNG Aviation Support Facility #1.....	99	U.S. Army Garrison - Humphreys.....	109
Kentucky ARNG.....	86	Tennessee ARNG Aviation Support Facility #2.....	98	U.S. Army Garrison, Fort Novosel.....	56
Louisiana ARNG.....	87	Tennessee ARNG Aviation Support Facility #3.....	98	U.S. Army Human Resources Command.....	86
Maine ARNG.....	87	Texas ARNG Aviation Support Facility #3 (DAASF).....	102	U.S. Army Intelligence Center & Fort Huachuca.....	72
Maryland ARNG.....	87	The Joint Staff, J-3, Regional Operations and Force Management.....	78	U.S. Army Materiel Command (AMC).....	64
Massachusetts ARNG.....	89	The Joint Staff, J-5, Security Cooperation Coordination Division.....	78	U.S. Army Medical Evacuation Concepts & Capabilities Division (MECCD).....	62
Michigan ARNG.....	89	Tobyhanna Army Depot (TYAD).....	97	U.S. Army North/5th U.S. Army (ASCC) G-3 Air Division.....	101
Minnesota ARNG.....	89	TRADOC Safety Office.....	104	U.S. Army North/Fifth U.S. Army (ARNORTH).....	102
Mississippi ARNG.....	90	U.S. Africa Command (USAFRICOM).....	107	U.S. Army Pacific (USARPAC).....	81
Missouri ARNG.....	91	U.S. Army Aeromedical Research Laboratory (USAARL).....	62	U.S. Army Priority Air Transport Command (USAPAT).....	89
Montana ARNG.....	91	U.S. Army Aeronautical Services Agency (USAASA).....	103	U.S. Army Reserve Avn. Cmd. (ARAC).....	85
Nebraska ARNG.....	91	U.S. Army Aeronautical Services Det.-Europe (USAASD-E).....	107	U.S. Army Reserve Command (USARC).....	95
Nevada ARNG.....	91	U.S. Army Air Traffic Services Command (ATSCOM).....	62	U.S. Army School of Aviation Medicine (USASAM).....	60
New Hampshire ARNG.....	92			U.S. Army South.....	101
New Jersey ARNG.....	92			U.S. Army South/6th Army (ASCC) G-3 Air Branch.....	102
New Mexico ARNG.....	92			U.S. Army Spec. Ops. Avn. Cmd. (USASOAC)(ARSOAC).....	95
New York ARNG.....	93			U.S. Army Special Operations Command (USASOC).....	94
North Carolina ARNG.....	95			U.S. Army Test and Evaluation Command (USATEC).....	87
North Dakota ARNG.....	96			U.S. Army Test, Measurement & Diagnostic Equip. Activity (USATA).....	64
Ohio ARNG.....	96			U.S. Army Training and Doctrine Command (TRADOC).....	104



AAA Aircraft Survivability Equipment Symposium



Sponsored by Army Aviation Association of America

THANK YOU SPONSORS



Networking Lunch



WIFI



Co-Branded Lanyard

U.S. Army Contracting Command.....	70	Vermont ARNG Aviation Support Facility.....	103
U.S. Army DEVCOM C51SR CENTER.....	92	Virgin Islands ARNG Aviation Operating Facility.....	107
U.S. Army Europe, G-3, Aviation Division.....	107	Virginia ARNG Aviation Support Facility.....	105
U.S. Army Europe, G-4, Aviation Office.....	107	WAATS Aviation Support Battalion.....	74
U.S. Army Evaluation Center (USAEC).....	87	WAATS Maintenance Battalion.....	74
U.S. Army Fixed Wing Project Office.....	68	WAATS Total Army School System Bn. (TASS)7.....	74
U.S. Army Flight Operations Detachment (AFOD).....	107	West Virginia ARNG Aviation Support Facility #1.....	106
U.S. Army Flight Tng. Det. - Peace Vanguard.....	72	West Virginia ARNG Aviation Support Facility #2.....	106
U.S. Army Forces Command (FORSCOM).....	94	Western Army National Guard Aviation Training Site (WAATS).....	74
U.S. Army Futures Command (AFC).....	99	Wheeler-Sack Army Airfield.....	94
U.S. Army Garrison - Humphreys.....	109	Wisconsin ARNG Aviation Support Facility #1.....	106
U.S. Army Garrison, Fort Novosel.....	56	Wisconsin ARNG Aviation Support Facility #2.....	106
U.S. Army Human Resources Command.....	86	Yuma Proving Ground.....	74
U.S. Army Intelligence Center & Fort Huachuca.....	72		
U.S. Army Materiel Command (AMC).....	64		
U.S. Army Medical Evacuation Concepts & Capabilities Division (MECCD).....	62		
U.S. Army North/5th U.S. Army (ASCC) G-3 Air Division.....	101		
U.S. Army North/Fifth U.S. Army (ARNORTH).....	102		
U.S. Army Pacific (USARPAC).....	81		
U.S. Army Priority Air Transport Command (USAPAT).....	89		
U.S. Army Reserve Avn. Cmd. (ARAC).....	85		
U.S. Army Reserve Command (USARC).....	95		
U.S. Army School of Aviation Medicine (USASAM).....	60		
U.S. Army South.....	101		
U.S. Army South/6th Army (ASCC) G-3 Air Branch.....	102		
U.S. Army Spec. Ops. Avn. Cmd. (USASOAC)(ARSOAC).....	95		
U.S. Army Special Operations Command (USASOC).....	94		
U.S. Army Test and Evaluation Command (USATEC).....	87		
U.S. Army Test, Measurement & Diagnostic Equip. Activity (USATA).....	64		
U.S. Army Training and Doctrine Command (TRADOC).....	104		
U.S. Army Warrant Officer Career College.....	60		
U.S. Army White Sands Missile Range (WSMR).....	92		
U.S. Military Academy Civil and Mechanical Engineering Academic Flight Program.....	94		
U.S. Military Academy Flight Detachment.....	93		
U.S. Northern Command (NORTHCOM).....	77		
U.S. Southern Command (USSOUTHCOM).....	79		
U.S. Special Operations Command.....	80		
U.S. States Corps of Cadets.....	94		
Uncrewed Aircraft Systems (UAS) Project Office.....	68		
Unmanned Aircraft System Flight Center.....	90		
Unmanned Aircraft Test Div., Avn. Test Dir., USAOTC Plans and Analysis.....	101		
USAACE Army National Guard Staff.....	56		
USAACE G.....	56		
USAACE G-5.....	56		
USAACE Liaison Office.....	56		
USAASA - Central Service Area Department of the Army Representative (CSA - DAR).....	101		
USAPAT Pacific Flight Detachment.....	82		
Utah ARNG Aviation Support Facility.....	102		
Utility Helicopters Project Office, PEO AVN.....	68		

WHEN MISSION READINESS MATTERS MOST



REVOLUTIONARY ELECTRICAL TESTING TECHNIQUES

DETERMINES

Root Cause of Failure (No Repeat Failures)

ELIMINATES

No Fault Found (NFF)
Can Not Duplicate (CND)
Intermittent Symptoms

REDUCES

Pilot Reported Discrepancies (PRD's)
False Removal Rates
Overall Avionic Consumption



ECLYPSE
INTERNATIONAL

www.eclipse.org

*LEADING THE
FUTURE OF TEST*

www.eclipse.org
sales@eclipse.org
(951) 371-8008



North Atlantic
Industries



SIU34
Sensor Interface Unit



NIU3E
Nano Interface Unit

High Accuracy Detection Exploitation System (HADES) Digital Backbone Nodal Access Units feature NIU3E and SIU34!

Nano Interface Unit (NIU3E) and Sensor Interface Unit (SIU34) serve as the core components facilitating seamless communication between various standard aircraft interfaces, including MIL-STD-1553, ARINC-429, RS-232/422/485, CANBus, Digital-to-Analog, Analog-to-Digital, Discrete IO, and Ethernet-based sensors, and the high-speed digital backbone Ethernet on the High Accuracy Detection Exploitation System (HADES) aircraft. These units provide critical support to the Digital Backbone Nodal Access Units (NAU), effectively bridging the gap between standard aircraft interfaces and the high-speed digital backbone. By integrating DornierWorks Time Sensitive Network (TSN) deterministic Ethernet IP with DDC-I Deos DO-178C DAL A Certifiable ARINC-653 RTOS, the NIU3E and SIU34 ensure smooth communication and time synchronization of sensor data throughout the entire digital backbone.



North Atlantic
Industries
www.naii.com



100% Designed, Manufactured,
Assembled and Tested in the U.S.A





**SIMULATOR
PRODUCT
SOLUTIONS**
LLC

Soar To Greater Heights With The Premier Simulation Product & Services Provider

Proudly supplying the US and friendly militaries, prime contractors, and systems integrators with cutting-edge high-fidelity grips, lighted panels and bezels, displays, touchscreen displays, keyboards, test sets, and ancillary simulation and training products and software solutions.



BECAUSE LIVES DEPEND ON OUR PRODUCTS

Breeze-Eastern's next-generation Four-Strand Cable is a certified, patented, form, fit, and functional replacement for current industry standard cables. Categorized by superior performance capabilities, improved resilience, and lower lifecycle costs, the Four-Strand offers industry-leading support for demanding mission scenarios and operator safety.

RESCUE HOISTS | WINCHES | CARGO HOOKS | WEAPONS HANDLING SYSTEMS

+1-973-602-1001 BREEZE-EASTERN.COM



SUPPORTING CRITICAL AVIATION SYSTEMS FOR 80 YEARS

ANTENNAS ELECTROSTATICS LIGHTNING PROTECTION

DAYTON-GRANGER
ANTENNAS, ELECTROSTATICS AND LIGHTNING PROTECTION

Excellence in Aerospace since 1943

sales@daytongranger.com (954) 463-3451 www.daytongranger.com

FREEMAN HOLDINGS GROUP



MILLION AIR®

*AEX | *CWF | **FOE | *HSA | **MWH
 *MFR | **NYL | *RIV | *RME | *SFB
 *SGU | *SYR | *VCV | **PHJR

FREEMAN JET CENTER FJC

*ARA | *ESF | LCH | *PUB | *SYR

ACIJET

*PRB | *SBP | SNA
 * LOCATION HOLDS DLA CONTRACT
 ** RAPID REFUELING AVAILABLE

LEARN MORE ABOUT OUR LUXURY FBO LOCATIONS AT
WWW.FREEMANHOLDINGSGROUP.COM

MNG
 Ministry of National Guard
 Kingdom of Saudi Arabia

Apply Today!

Vinnell Arabia
 Vinnell Arabia, LLC is a Saudi Arabian registered, single shareholder limited liability corporation, as a wholly-owned subsidiary of the Northrop Grumman Corporation.

Positions available in Saudi Arabia for immediate Hire!

Visit our Booth #801 at the Army Mission Solutions Summit April 24-26, 2024 in Denver, CO

**Vinnell Arabia is Hiring
 IPs, MTPs, Mechanics and Managers
 AH64E, AH6i, UH60M and MD530**

Join us!

www.vinnellarabia.com



RECOIL

TRUSTING YOUR 40-YEAR-OLD LOGISTICS TO GET YOU HOME?

MODERNIZE

U1000

The U1000 closes the logistic capability-gap as a durable, dual-use, light weight, liquid product cargo tank, supporting multiple mission requirements. It is 463L pallet compatible supporting rapid air or ground transportation.

ROTORCRAFT

CH-47 | CH-53 | S-92 | AW189K

FIXED WING

C-130 | AQ400 | C-17 | C-27J | CN235

RECOIL = Mission Readiness



YULISTA

An Alaskan Native Corporation 8(a)

AVIATION • MARITIME • GROUND • MISSILES • RANGE OPS • BASE OPS • AEROSPACE • TECH

MODERNIZING AVIATION FOR THE WARFIGHTER

Yulista integrates our Nation's modernization priorities throughout the Army Aviation Enterprise. Every day, Yulista's technical experts deliver aviation weapon systems and ground support equipment that enhances the lethality, survivability, and maintainability our Army's weapon systems.

Together, we proudly serve the Aviation Warfighter on and off the battlefield.

- SYSTEM DESIGN & INTEGRATION
- ENGINEERING & MANUFACTURING
- MAINTENANCE & MODIFICATIONS
- TRAINING & TECHNICAL PUBLICATIONS
- TRAINING SYSTEMS & SOLUTIONS
- BASE & RANGE OPERATIONS
- CYBER & INFORMATION TECHNOLOGIES



Learn more about working with Yulista and flexible 8(a) contracting.

#WEAREYULISTA

ISO9001 AS9100 AS9110 CERTIFIED – CERTIFIED FAA PART 145 REPAIR STATIONS

YULISTA.COM

PBS TURBOJET ENGINES

BEST SOLUTION FOR UAVs
& TACTICAL SYSTEMS

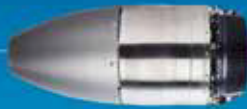

PBS AEROSPACE INC.
SMALL GAS TURBINE OEM
ATLANTA, GA, UNITED STATES

WWW.PBSAEROSPACE.COM



ARMY AVIATION MUSEUM FOUNDATION

PROUDLY SUPPORTING THE U.S. ARMY AVIATION MUSEUM SINCE 1970

MUSEUM & GIFT SHOP

Subscribe to Our
 YouTube
Channel

MONDAY - FRIDAY 9 - 4

SATURDAY 9 - 3

GIFT SHOP CLOSES AT 2:45 ON SATURDAYS

Shop In-Store
& Online!

*Your Contributions Make
a Difference!*

DONATE NOW!



*See You at
Cibola!*



WWW.ARMYAVIATIONMUSEUM.ORG
WWW.YOUTUBE.COM/@ARMYAVIATIONMUSEUMFOUNDATION



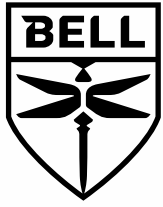

BELL 360 INVICTUS | FUTURE ATTACK RECONNAISSANCE AIRCRAFT

**FIND.
FIX.
FINISH.**



Purpose-built for deep reconnaissance with open architecture allowing rapid, affordable upgrades, the Bell 360 is a lethal and survivable weapon system that retains the freedom to maneuver.

Learn more at bell.co/360

BUILDING THE

FUTURE

WITH

ARMY AVIATION



Tyonek is hard at work building the future. We added new facilities and faster precision machines to deliver more OEM-quality avionics, electronics, and mechanical components for aviation and ground systems. We expanded our hangars to meet the demands for maintenance and modification on Army, other DoD, and FMS aircraft. We designed and fielded new products to meet current needs and help defend against tomorrow's threats.

Tyonek is proud to build the future with Army Aviation.

BUILD THE FUTURE WITH US.

Visit www.Tyonek.com/careers

- Logistics Support Facility (LSFMA-V) Prime Contractor
- Redstone Test Center Aviation Management Support Service Prime Contractor
- BAE Systems Small Business Supplier of the Year
- Lockheed/Sikorsky Elite Supplier
- Lockheed/Sikorsky Supplier of the Year (Black Hawk)
- Lockheed Martin RMS Outstanding Small Business



S·A·F·E

— STRUCTURE DESIGNS —

JOHN 13:7

CREATIVE PROJECT SOLUTIONS THROUGH DESIGN, ENGINEERING, AND MANUFACTURING



AIR • LAND • SEA • SPACE

**ZERO NRE
FOR DESIGN**



Contract Holder
Contract 47QSWA20D002L



9001:2015

**QUALITY
CERTIFIED**

702.809.1146 | SAFESTRUCTUREDESIGNS.COM | SALES1@SAFE-2.COM

AAAA SCHOLARSHIP PROGRAM



SCHOLARSHIP PROGRAM IS **OPEN**
DEADLINE DECEMBER 15



Applications and
additional information:
www.quad-a.org/scholarship

+ 61st Year Giving Scholarships

+ \$10.3 Million Gifted





Over \$650,000 Awarded by the AAAA Scholarship Foundation – Its Largest Program to Date!

By COL (Ret.) Karen Lloyd

The Army Aviation Association of America Scholarship Foundation, Inc. (AAAASFI) is proud to announce the selection of 401 deserving Army Aviation Association of America (AAAA) family members to receive \$651,000 in scholarship grants.

Your scholarship foundation has come a long way since its inception in 1963 when the first scholarship grant of \$1,500 was awarded to Joel Graft.

Scholarships are the most important AAAA membership benefit and to date AAAASFI has awarded more than \$10.3M to over 6,400 recipients.

In 2015 we transitioned to a fully electronic voting process which means you can complete your application evaluation from anywhere. We thank everyone who took the time this year to assist in this very important process. If you don't have someone competing for a scholarship, please consider becoming an evaluator.

During the selection process, students are judged solely on their own merit. All references to names, units, location or to a relative member's rank/title are removed from the files before board review and are only revealed after all files have been voted and selections made by order of merit list has been completed.

This year there were 631 applicants that completed the application with a selection rate of approximately 56%. As in previous years, the competition was tough with 61% of freshmen attaining a 4.0 or higher-grade point average (GPA).

The success rates for applicants based on the member affiliate's demographic group were:

- 52% of enlisted applicants that applied won awards
- 53% of warrant applicants that applied won awards
- 69% of commissioned applicants that applied won awards
- 70% of civilian applicants that applied won awards

This year we saw 39 of our 76 AAAA chapters participate in the annual Chapter Matching Program. This program allows our chapters to raise money and have it matched by the Scholarship Foundation based on their chapter size. For our AAAA and Senior chapters the match is up to \$5,000, for our Master chapters it is up to \$4,000 and our Super chapters the match is up to \$3,000.

A key take-away is that 100 percent of your donations go directly to scholarships because AAAA pays overhead costs less management fees of the Scholarship Foundation (a separate corporation). Please ask your chapter officers for more information and encourage your local chapter leadership to sponsor a scholarship for your own chapter, if there isn't one already. Let's get the remaining 37 chapters into the program.

The **Annual AAAA Scholarship Fundraising Dinner and Silent Auction**, will take place on Tuesday, November 14, 2023, during the Cribbins Army Aviation Readiness Symposium in Huntsville, AL. Join us for a fun-filled evening as we stroll down memory lane to music from the 60's and 70's all while supporting AAAA families.

Right now, take a few moments to look through the following pages and join me in congratulating our most deserving 2023 awardees. If you have any questions about the program, contact us at (800) 722-ARMY, or scholarship@quad-a.org.

*COL (Ret.) Karen Dahlgren Lloyd
President, AAAA Scholarship Foundation, Inc.*



Helen Cribbins Memorial Perpetual Scholarship
\$10,500 - \$2,625 for 4 years - Bianca Lorraine G Osterling - Daughter of Mr. Gabriel Osterling, Mesa AZ - Stanford University



Joseph P. Cribbins Memorial Perpetual Scholarship
\$10,500 - \$2,625 for 4 years - Caleb M Hatch - Son of LTC Shawn Hatch, Colorado Springs CO - University of Colorado Boulder



AIRBUS Group Corporate Perpetual Matching Scholarship
\$6,000 - \$1,500 for 4 years - Zachary M Taylor - Grandchild of LTG John Curran, Hudson Oaks TX - Texas A&M University



AAAA National BG O. Glenn Goodhand Memorial Scholarship
\$5,000 - \$1,250 for 4 years - Ella R Duus - Daughter of COL Andrew Duus, Huntsville AL - Georgetown University



AAAA National BG Robert M. Leich Memorial Scholarship
\$5,000 - \$1,250 for 4 years - Caroline E Pickett - Daughter of LTC Mark Pickett, Raleigh NC - University of North Carolina Chapel Hill



AAAA National Bryce Wilson Memorial Scholarship
\$5,000 - \$1,250 for 4 years - Bethany B Brock - Grandchild of LTC Connor Dotson, Huntsville TX - Texas A&M University - College Station



Connecticut Chapter (LTC William J. May Memorial) Scholarship
\$4,000 for 1 year - Katrina B Tozier - Daughter of CW4 David Tozier, East Haddam CT - Merrimack College

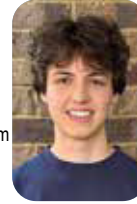

Tennessee Valley Chapter (COL Joseph A. Hoecherl Memorial) Perpetual Matching Scholarship
\$4,000 for 1 year - Matthew Charles Mings, Madison, AL - Georgetown University



Tennessee Valley Chapter (Colleen Hipp Memorial) Perpetual Matching Scholarship
\$4,000 for 1 year - Stella E Stephens - Daughter of COL Gary Stephens, Brownsboro AL - University of Georgia



Tennessee Valley Chapter Perpetual Matching Scholarship
\$4,000 for 1 year - Vivian S Wu - Daughter of Mr. Meng Wu, Madison AL - Auburn University



LTG Gus Cianciolo Memorial Scholarship
\$4,000 for 1 year - Kathryn C Lang - Daughter of LTC Jarred Lang, Fairfax VA - Florida State University

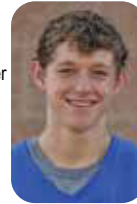

AAAA National Aeronautical Sciences Scholarship
\$4,000 for 1 year - Andrew C Brady - Son of MAJ James Brady, Fort Leavenworth KS - Kansas State University



Central Florida (SGT Dan E Hackney) Chapter Matching Scholarship
\$3,500 for 1 year - Alexa L Lacy - Daughter of COL Benjamin Lacy, Merritt Island FL - Wake Forest School of Medicine



GEN Frank S. Besson, Jr. Memorial Perpetual Scholarship
\$3,000 - \$1,750 for 2 years - Aaron J Brokovich - Grandchild of COL Michael Brokovich, Abilene TX - Massachusetts Institute of Technology



LTG William B. Bunker Memorial Perpetual Scholarship
\$3,000 - \$1,750 for 2 years - Zachary C Ballam - Grandchild of CAPT Robert Palmer, Pleasant View UT - Brigham Young University



Bell Textron Corporate Perpetual Matching Scholarship
\$3,000 - \$1,750 for 2 years - Taylor Morgan Martini - Daughter of LTC Noma Martini, Keller TX - Baylor University



BG James and Joyce Hesson Scholarship
\$3,000 - \$1,750 for 2 years - Asel R Ballew - Daughter of CW4 Joshua Ballew, Enterprise AL - The University of Alabama

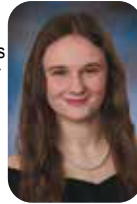

Tennessee Valley Chapter (Maxwell Harris Guida Memorial) Perpetual Matching Scholarship
\$3,000 for 1 year - Tara A Flynn - Daughter of Mr. Tim Flynn, Madison AL - Auburn University



Washington-Potomac Chapter (SPC Jeremy D. Tomlin) Perpetual Matching Scholarship
\$3,000 for 1 year - William W McIntosh - Son of COL Travis McIntosh, Fairfax Station VA - The Citadel



Washington-Potomac Chapter (COL Harry W. Townsend) Perpetual Matching Scholarship
\$3,000 for 1 year - Aidan M Cullinan - Son of COL Brendan Cullinan, Arlington VA - Gettysburg College



Washington-Potomac Chapter (COL Paul Kelly) Perpetual Matching Scholarship
\$3,000 for 1 year - Peter T Daood - Grandchild of COL Curt Herrick, Fort Belvoir VA - Creighton University



Washington-Potomac Chapter (LTG Harry Kinnard) Perpetual Matching Scholarship
\$3,000 for 1 year - Fernando R. Avila - Son of CW5 Fernando Avila-Gonzalez, Waldorf MD - Embry-Riddle Aeronautical University

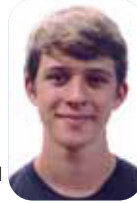

Washington-Potomac Chapter (LTG Lavern E. Weber and LTC Donald L. Wellen) Perpetual Matching Scholarship
\$3,000 for 1 year - Caleb J Pipes - Son of COL Gregory Pipes, Dulles VA - Grove City College



Washington-Potomac Chapter (MG Carl McNair) Perpetual Matching Scholarship
\$3,000 for 1 year - Lillian G Beall - Daughter of Mr. Scott Beall, Arlington VA - James Madison University



Washington-Potomac Chapter (MG Robert F. Molinelli) Perpetual Matching Scholarship
\$3,000 for 1 year - Sophia M Bricker - Daughter of COL Paul Bricker, Clifton VA - Marymount University

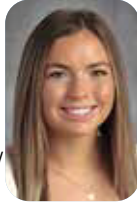

Robertson Fuel Systems, LLC (John R. Rawling) Corporate Perpetual Matching Scholarship
\$3,000 for 1 year - Ava E Ballam - Grandchild of CAPT Robert Palmer, Pleasant View UT - Brigham Young University



Morgan Rae Kurowsky Memorial Scholarship
\$3,000 for 1 year - Bailey Williams - Daughter of Mrs. Kimberly Williams, Mesa AZ - Point Loma Nazarene University



COL (Ret.) Paul B. and Jenny L. Gale Memorial Perpetual Scholarship
\$2,500 for 1 year - Sydney A Crocetta - Grandchild of LTC Clarence Boyle, Williamsburg VA - University of Lynchburg



Connecticut Chapter I Perpetual Matching Scholarship
\$2,500 for 1 year - William T Kaye - Son of Mr. Tom Kaye, Clinton CT - Georgia Institute of Technology



Connecticut Chapter II Perpetual Matching Scholarship
\$2,500 for 1 year - Grace Cerneck - Daughter of CAPT Michael Cerneck, Southbury CT - Virginia Tech



Mid-Atlantic/Monmouth Chapter Perpetual Matching Scholarship
\$2,500 for 1 year - Lauren R Rautenberg - Daughter of LTC Erik Rautenberg, Phillipsburg NJ - Purdue University



Vietnam Helicopter Pilots Association (VHPA) Heritage Matching Scholarship
\$2,500 for 1 year - Alexis K Wasserberg - Grandchild of CW5 Richard Hanusa, Oshkosh WI - Augustana College

AAAA Scholarship Foundation Inc. 2023 Awardees



Vietnam Helicopter Pilots Association (VHPA) Heritage Matching Scholarship
\$2,500 for 1 year - Caleb J Youngstedt - Grandchild of CPT Glenn Youngstedt, Saint Joseph MI - Hillsdale College



Vietnam Helicopter Pilots Association (VHPA) Heritage Matching Scholarship
\$2,500 for 1 year - Tyler J Peeler - Grandchild of CW4 Timothy Kavanaugh, Centerville OH - Florida State University



Vietnam Helicopter Pilots Association (VHPA) Heritage Matching Scholarship
\$2,500 for 1 year - Evan R Olson - Grandchild of Mr. Evan Olson, Plano TX - Samford University



Vietnam Helicopter Pilots Association (VHPA) Heritage Matching Scholarship
\$2,500 for 1 year - Jillian L Vincent - Grandchild of COL Gary Downs, New Braunfels TX - Hillsdale College



Vietnam Helicopter Pilots Association (VHPA) Heritage Matching Scholarship
\$2,500 for 1 year - Hanna E Carlsson - Grandchild of LTC Lance Hiltbrand, Edmond OK - Stanford University



Vietnam Helicopter Pilots Association (VHPA) Heritage Matching Scholarship
\$2,500 for 1 year - Mason C McCart - Grandchild of CW4 David Sheppard, Enterprise AL - University of Notre Dame



Vietnam Helicopter Pilots Association (VHPA) Heritage Matching Scholarship
\$2,500 for 1 year - Stacy C Whitwell - Grandchild of CW4 Jim Whitwell, Folsom CA - Lipscomb University



Vietnam Helicopter Pilots Association (VHPA) Heritage Matching Scholarship
\$2,500 for 1 year - Addison S Levy - Grandchild of CPT Charles Bayless, Lawrenceville GA - University of Tennessee



Vietnam Helicopter Pilots Association (VHPA) Heritage Matching Scholarship
\$2,500 for 1 year - Marie A Hamilton - Grandchild of Ms. Marie Hamilton, Canyon Country CA - University of Santa Barbara



Vietnam Helicopter Pilots Association (VHPA) Heritage Matching Scholarship
\$2,500 for 1 year - Logan A Bentley - Grandchild of LTC Aubrey Bentley, Sorrento FL - University of Alabama



Vietnam Helicopter Pilots Association (VHPA) Heritage Matching Scholarship
\$2,500 for 1 year - Hudson L Serletic - Grandchild of MAJ Matthew Serletic, Eatonton GA - Columbia University



Vietnam Helicopter Pilots Association (VHPA-361st AVN Co "Pink Panthers") Heritage Matching Scholarship
\$2,500 for 1 year - Reagan G Richeson - Grandchild of CW4 Jeffrey Richeson, Baltimore OH - Slippery Rock University



Vietnam Helicopter Pilots Association (VHPA-Anonymous Donor) Heritage Matching Scholarship
\$2,500 for 1 year - Ainslee M Cruce, Bowling Green, KY - University of The Cumberlands



Vietnam Helicopter Pilots Association (VHPA-Helene Westreich Memorial) Heritage Matching Scholarship
\$2,500 for 1 year - Madelyn J Whiteing - Grandchild of Capt Leonard Whiteing, Omaha NE - Univ. of Nebraska Lincoln



Vietnam Helicopter Pilots Association (VHPA-IMO UPI Reporter Joe Galloway) Heritage Matching Scholarship
\$2,500 for 1 year - Carrie A. Byars - Grandchild of LTC Harold Byars, Newport News VA - Texas A&M University



Vietnam Helicopter Pilots Association (VHPA MG Carl H. McNair Jr., Ret) Heritage Matching Scholarship
\$2,500 for 1 year - Madelyn L Swartz - Grandchild of CW5 Richard Crosley, Pottstown PA - Virginia Polytechnic Institute and State Univ.



Vietnam Helicopter Pilots Association (VHPA-MG Carl H. McNair Jr., Ret) Heritage Matching Scholarship
\$2,500 for 1 year - Madelyn M Diep - Grandchild of CW4 Ransom Beckwith, Liverpool NY - Keuka College

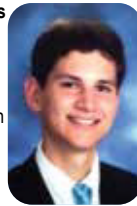

Connecticut Chapter Matching Scholarship
\$2,500 for 1 year - Justin R Sadownick - Son of CW4 Ronald Sadownick, Monroe CT - Hackensack Monroee School of Medicine



Connecticut Chapter Matching Scholarship
\$2,500 for 1 year - Chrissy Chow - Daughter of Mr. James Chow, Wallingford CT - University of New England College of Osteopathic Medicine



Great Lakes Chapter (CW5 Thomas McBeath) Matching Scholarship
\$2,500 for 1 year - Haley L Crawford - Daughter of CPT Gregory Crawford, Midland MI - University of Detroit Mercy



Great Lakes Chapter (CW5 Thomas McBeath) Matching Scholarship
\$2,500 for 1 year - Jacob W Weber - Grandchild of Mr. Jacob Weber, Canton MI - Michigan State University



100 Black Men-VA Peninsula Chapter Founder's (Washington Potomac Chapter) Perpetual Matching Scholarship
\$2,000 for 1 year - Darius A McCallum - Son of Ms. Kathy Parker, Newport News VA - University of California San Diego



Air Assault Chapter (COL Henry "Hawk" Ruth, Ret.) Perpetual Matching Scholarship
\$2,000 for 1 year - Alauna I Wilson - Daughter of CPT John Wilson, Statesville NC - West Virginia Wesleyan College



Air Assault Chapter (COL Ted Crozier) Perpetual Matching Scholarship
\$2,000 for 1 year - Emma M Karls - Daughter of CW5 Justin Karls, Adams TN - University of Tennessee at Knoxville



Tennessee Valley Chapter (Christopher and William "Bill" Gavora Memorial) Perpetual Matching Scholarship
\$2,000 for 1 year - Lindsay E VanKirk - Grandchild of LTC Jack Van Kirk, Madison AL - Auburn University



Tennessee Valley Chapter (COL Bill Powell Memorial) Perpetual Matching Scholarship
\$2,000 for 1 year - Benjamin B. Frasier - Son of COL Johnathan Frasier, Athens AL - University of North Alabama (UNA)

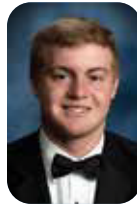

Tennessee Valley Chapter (CSM Isaac B. Sheffield Memorial) Matching Scholarship
\$2,000 for 1 year - Dylan L Hyatt - Son of Ms. Leslie Hyatt, Huntsville AL - University of Alabama



Tennessee Valley Chapter (CW4 James V. Torney Memorial) Matching Scholarship
\$2,000 for 1 year - Hallie R Logan - Daughter of Mr. Brent Logan, Owens Cross Roads AL - Auburn University



Tennessee Valley Chapter (Dianne Stephenson Memorial) Matching Scholarship
\$2,000 for 1 year - Katherine G Marlow - Daughter of 1SG Jeffery Marlow, Harvest AL - Auburn University



Tennessee Valley Chapter (John K. Jolly Memorial) Matching Scholarship
\$2,000 for 1 year - Madelynn Lewis - Daughter of Mrs. Lynn Lewis, Huntsville AL - Mississippi State University



Tennessee Valley Chapter (LTC Steven D. Moore) Perpetual Matching Scholarship
\$2,000 for 1 year - Chase R Guida - Son of COL Spencer Guida, Owens Cross Roads AL - Carnegie Mellon University



Tennessee Valley Chapter (MAJ Jeffrey DeCarlo Memorial) Matching Scholarship
\$2,000 for 1 year - Noland R Miller - Son of MSG Scott Miller, Huntsville AL - University of Alabama

AAAA Scholarship Foundation Inc. 2023 Awardees



Tennessee Valley Chapter (Mary and John Burke:Excellence in Engineering) Perpetual Matching Scholarship
\$2,000 for 1 year - Tyler D Hyatt - Son of Ms. Leslie Hyatt, Huntsville AL - University of Alabama



Tennessee Valley Chapter (Paul Bogosian) Matching Scholarship
\$2,000 for 1 year - Stuart H Ramsey - Son of LTC Andrew Ramsey, Huntsville AL - William and Mary



Tennessee Valley Chapter (Stan Cagle Memorial) Perpetual Matching Scholarship
\$2,000 for 1 year - Riley S Foster - Grandchild of COL Rayford Eubanks, New Marketq AL - Mississippi State University



Boeing Corporate Perpetual Matching Scholarship
\$2,000 for 1 year - Ryan Christopher Billmann - Son of Mr. Kevin Billmann, Swedesboro NJ - Virginia Tech



S3 Inc-System Studies and Simulation, Inc. Corporate Perpetual Matching Scholarship
\$2,000 for 1 year - Xavier A Soto - Son of CW5 Guillermo Soto, Huntsville AL - The University of Alabama at Birmingham



Sikorsky (Igor Sikorsky) Corporate Perpetual Matching Scholarship
\$2,000 for 1 year - Kathryn A Semosky - Sibling of Mr. Matthew Lisk, Watertown CT - Post University

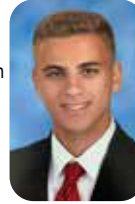

Sikorsky II (Igor Sikorsky) Corporate Perpetual Matching Scholarship
\$2,000 for 1 year - Anthony J Fiatarone - Son of Mr. Dana Fiatarone, Stratford CT - Bentley University



Vertol Systems Company Corporate Perpetual Matching Scholarship
\$2,000 for 1 year - Kathryn Kilian Miller - Daughter of COL Jacob Miller, Williamsburg VA - The University of Notre Dame



114th Aviation Company Heritage Matching Scholarship
\$2,000 for 1 year - Victoria G Brown - Grandchild of COL Robert Brown, San Antonio TX - Virginia Commonwealth University



Otter-Caribou Heritage Matching Scholarship
\$2,000 for 1 year - Joel L Beaugreud, Weatherford, TX - University of Texas - Austin



Otter-Caribou Heritage Matching Scholarship
\$2,000 for 1 year - Kylee Bennett - Grandchild of Ms. Kylee Bennett, Pocatello ID - Embry-Riddle Aeronautical University

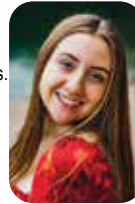

Otter-Caribou Heritage Matching Scholarship
\$2,000 for 1 year - Lily Givens, Coeur d'Alene, ID - University of Idaho



COL James W. Lloyd, Ret. Memorial Scholarship
\$2,000 for 1 year - Sarah E Bergantz - Grandchild of MG Joseph Bergantz, Madison AL - Clemson University



CW4 Richard E. Campbell Memorial Scholarship
\$2,000 for 1 year - Bailey D Phillips - Daughter of CW5 Douglas Phillips, Azle TX - Texas Tech University



CW5 Lee M. Tutin Memorial Scholarship
\$2,000 for 1 year - Allison Schuck - Daughter of COL Gerald Schuck, APO AE - University of Virginia

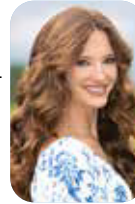

CW5 Lee M. Tutin Memorial Scholarship
\$2,000 for 1 year - Ella Hogan - Grandchild of CW4 Roger Hogan, Enterprise AL - Auburn University



CW5 Lee M. Tutin Memorial Scholarship
\$2,000 for 1 year - Sydney M Gabhart - Daughter of CW5 Shawn Gabhart, Frankfort KY - University of Kentucky



CW5 Lee M. Tutin Memorial Scholarship
\$2,000 for 1 year - Anna E Davis - Daughter of COL Tom Davis, Tucson AZ - Arizona State University



MG Ostovich and Lucky Wright Scholarship
\$2,000 for 1 year - Ryan A Lukow - Spouse of COL Ronald Lukow, Fairfax Station VA - Purdue University



Arizona Chapter Dimmery-Koch Memorial Matching Scholarship
\$2,000 for 1 year - McKenzie C Cox - Grandchild of COL David Sale, Mesa AZ - University of Kentucky



Arizona Chapter Dimmery-Koch Memorial Matching Scholarship
\$2,000 for 1 year - Samuel Webster - Son of Lt Co John Webster, Gilbert AZ - Arizona State University



Arizona Chapter Dimmery-Koch Memorial Matching Scholarship
\$2,000 for 1 year - Demetrios E Pickett - Son of Mr. Brian Pickett, Chandler AZ - University of Arizona



Arizona Chapter Dimmery-Koch Memorial Matching Scholarship
\$2,000 for 1 year - Lauren Cox - Grandchild of COL David Sale, Mesa AZ - University of Utah



Arizona Chapter Dimmery-Koch Memorial Matching Scholarship
\$2,000 for 1 year - Sage Fletcher - Daughter of Mr. Drew Fletcher, Mesa AZ - Michigan State University



Big Sky Chapter Matching Scholarship
\$2,000 for 1 year - Gracie Leiva - Daughter of CW3 Jennnifer Hoover, Boulder MT - Montana State University



Bluegrass Chapter Matching Scholarship
\$2,000 for 1 year - Avery M Robinson - Daughter of LTC Phillip Robinson, Harrodsburg KY - Western Kentucky University



Bluegrass Chapter Matching Scholarship
\$2,000 for 1 year - Bailey N Robinson - Daughter of LTC Phillip Robinson, Harrodsburg KY - University of The Cumberland



Bluegrass Chapter Matching Scholarship
\$2,000 for 1 year - Kelly Nicole Gabhart - Daughter of CW5 Shawn Gabhart, Frankfort KY - University of Kentucky



Bluegrass Chapter Matching Scholarship
\$2,000 for 1 year - Raylan S Villier - Daughter of CW5 Anthony Villier, Lawrenceburg KY - Midway University



Central Florida Chapter (AVT Simulation) Matching Scholarship
\$2,000 for 1 year - Olivia Litaker - Daughter of CW5 Bernard Litaker, Odessa FL - University of Vermont



Central Florida Chapter (Cole Engineering) Matching Scholarship
\$2,000 for 1 year - Rana G Wyatt - Grandchild of CW4 John Wyatt, Orlando FL - University of Florida



Central Florida Chapter (Critical Design Associates) Matching Scholarship
\$2,000 for 1 year - Lucas A Vizzari - Son of COL Kevin Vizzari, Oviedo FL - Embry-Riddle Aeronautical University

AAAA Scholarship Foundation Inc. 2023 Awardees



Central Florida Chapter (DigiFlight) Matching Scholarship
\$2,000 for 1 year - Gene S Galke, Parkland, FL - University of Florida



Central Florida Chapter (Hatalom Corporation) Matching Scholarship
\$2,000 for 1 year - Jack S Carnahan - Grandchild of LTC William McElwee, Savannah GA - University of Tennessee

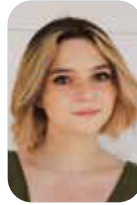

Central Florida Chapter (Industrial Smoke & Mirrors) Matching Scholarship
\$2,000 for 1 year - Corinna E Temple - Daughter of COL William Temple, Orange Park FL - University of North Florida



Central Florida Chapter (Microhealth) Matching Scholarship
\$2,000 for 1 year - Domenic A Vizzarri - Son of COL Kevin Vizzarri, Oviedo FL - University of South Florida



Central Florida Chapter (Semper Wealth) Matching Scholarship
\$2,000 for 1 year - Sophia K Cheros - Daughter of Mr. George Cheros, Sanford FL - The George Washington University-Milken School of Public Health



Central Florida Chapter (X Force) Matching Scholarship
\$2,000 for 1 year - Seamus Sweeney - Son of LTC Patrick Sweeney, Orlando FL - Dickinson College



Central Florida Chapter Matching Scholarship
\$2,000 for 1 year - Thomas M Quek, Tampa, FL - Liberty University

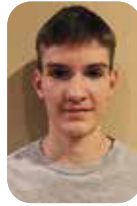

Central Florida Chapter Matching Scholarship
\$2,000 for 1 year - Logan M Wamsley - Grandchild of CW2 Gary Spooner, Mount Dora FL - University of South Carolina



Central Florida Chapter Matching Scholarship
\$2,000 for 1 year - Lucas C Wamsley - Grandchild of CW2 Gary Spooner, Mount Dora FL - University of South Carolina



Central Florida Chapter Matching Scholarship
\$2,000 for 1 year - Hannah G Wyatt - Grandchild of CW4 John Wyatt, Orlando FL - University of Florida



Central Florida Chapter Matching Scholarship
\$2,000 for 1 year - Luke C McCloud - Son of Mr. Terrell McCloud, Orlando FL - University of Florida



Central Florida Chapter Matching Scholarship
\$2,000 for 1 year - Isabella A Lewless - Grandchild of Ms. Cynthia Gallardo, Winter Park FL - Florida State University



Central Florida Chapter Matching Scholarship
\$2,000 for 1 year - Dylan C McCloud - Son of Mr. Terrell McCloud, Orlando FL - Florida State University



Idaho Snake River Chapter CPT Ed W. Freeman Memorial Matching Scholarship
\$2,000 for 1 year - Madeline Theresa Amthor - Daughter of LTC Granger Amthor, Meridian ID - Boise State University



Idaho Snake River Chapter CW2 Jesse D. Phelps Memorial Matching Scholarship
\$2,000 for 1 year - Jocelyn Charles Maxwell - Grandchild of SFC Kermit Morrison, Pocatello ID - College of Idaho



Idaho Snake River Chapter CW4 Jon L. Hartweg Memorial Matching Scholarship
\$2,000 for 1 year - Jenna Russell - Grandchild of Maj A. Russell, Sandpoint ID - Eastern Washington University



Idaho Snake River Chapter CW4 Stien P. Gearhart Memorial Matching Scholarship
\$2,000 for 1 year - Jacob Sauer - Son of LTC John Sauer, Boise ID - Boise State University



Old Tucson Chapter (1LT Steven J. Jordon Memorial) Matching Scholarship
\$2,000 for 1 year - Giselle Griffin - Daughter of 1SG Dirk Griffin, Tucson AZ - University of Arizona



Old Tucson Chapter (CW3 Gregory A. Clevenger Memorial) Matching Scholarship
\$2,000 for 1 year - Addison G Asbell - Grandchild of CW2 Robert Asbell, Oro Valley AZ - George Fox University



Old Tucson Chapter (LTC Benny Cobb Memorial) Matching Scholarship
\$2,000 for 1 year - Carson Lee Miller - Son of CW4 Dale Miller, Tucson AZ - University of the Southwest



Oregon Trail Chapter (Raymond F. Rees Leadership) Matching Scholarship
\$2,000 for 1 year - Kayla G Greenwood - Daughter of COL David Greenwood, Mount Angel OR - Pepperdine University



Southern California Chapter (COL Jake Benjamin Memorial) Matching Scholarship
\$2,000 for 1 year - Vance Jeffrey Sibley - Son of LTC Jeff Sibley, San Clemente CA - University of California - Los Angeles

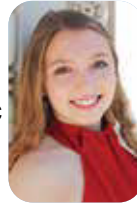

Tennessee Valley Chapter (Mr. Jeffrey L. Langhout) Matching Scholarship
\$2,000 for 1 year - Victoria J Yelverton - Grandchild of Mrs. Gail Davis, Huntsville AL - The University of Alabama



Tennessee Valley Chapter Matching Scholarship
\$2,000 for 1 year - Courtney S Steele - Daughter of Mr. Thomas Steele, Madison AL - The University of Alabama at Birmingham



Tennessee Valley Chapter Matching Scholarship
\$2,000 for 1 year - Benjamin C Lightfoot - Son of Dr. Jay Lightfoot, Huntsville AL - Auburn University



Tennessee Valley Chapter Matching Scholarship
\$2,000 for 1 year - Kristin J Hatch - Daughter of Mr. Jerry Hatch, Madison AL - Auburn University



Tennessee Valley Chapter Matching Scholarship
\$2,000 for 1 year - Mia M Beldner - Grandchild of Ms. Christine Henderson, Spring Hill FL - Catholic University of America



Tennessee Valley Chapter Matching Scholarship
\$2,000 for 1 year - Morgan E Hutson - Daughter of Mr. Dean Hutson, Huntsville AL - Auburn University



Tennessee Valley Chapter Matching Scholarship
\$2,000 for 1 year - Olivia L Cole - Daughter of Mr. Danny Russell, Huntsville AL - The University of Alabama



Tennessee Valley Chapter Matching Scholarship
\$2,000 for 1 year - Margaret Randle - Daughter of 1LT Timothy Randle, Huntsville AL - Auburn University



Tennessee Valley Chapter Matching Scholarship
\$2,000 for 1 year - Madison Thome - Daughter of COL Michael Thome, Hampton Cove AL - University of Alabama in Huntsville



Tennessee Valley Chapter Matching Scholarship
\$2,000 for 1 year - Carys E Gardner - Daughter of MAJ Mark Gardner, Lutz FL - University of Mississippi

AAAA Scholarship Foundation Inc. 2023 Awardees



Tennessee Valley Chapter Matching Scholarship
\$2,000 for 1 year - Ellary K Harbin - Daughter of Mr. Keith Harbin, Madison AL - University of Alabama



Tennessee Valley Chapter Matching Scholarship
\$2,000 for 1 year - Kyle R VanKirk - Grandchild of LTC Jack Van Kirk, Madison AL - Auburn University



Tennessee Valley Chapter Matching Scholarship
\$2,000 for 1 year - Claire B Lewis - Daughter of Mrs. Lynn Lewis, Huntsville AL - University of Tennessee at Knoxville



Tennessee Valley Chapter Matching Scholarship
\$2,000 for 1 year - Mia MR Edens - Daughter of BG Timothy Edens, Houston AL - Samford University



Tennessee Valley Chapter Matching Scholarship
\$2,000 for 1 year - Claudia P Stephens - Daughter of COL Gary Stephens, Brownsboro AL - Frederick P. Whiddon College of Medicine at the Univ. of South Alabama

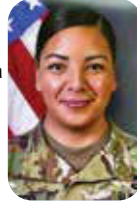

Tennessee Valley Chapter Matching Scholarship
\$2,000 for 1 year - Maria M Orozco, Huntsville, AL - Florida Institute of Technology



Tennessee Valley Chapter Matching Scholarship
\$2,000 for 1 year - Michael D Sorrell - Son of Mr. Robert Sorrell, Huntsville AL - The University of Alabama in Huntsville



Tennessee Valley Chapter Matching Scholarship
\$2,000 for 1 year - Jin-Shiuan T Wu - Daughter of Mr. Meng Wu, Madison AL - Auburn University



Tennessee Valley Chapter Matching Scholarship
\$2,000 for 1 year - Meredith E Ward - Daughter of COL Chad Ward, Athens AL - University of Alabama Huntsville



Tennessee Valley Chapter Matching Scholarship
\$2,000 for 1 year - Ashley C Bates - Daughter of Mr. Charles Bates, Meridianville AL - University of Alabama School of Medicine



Tennessee Valley Chapter Matching Scholarship
\$2,000 for 1 year - William T Atchley - Son of Mr. William Atchley, Owens Cross Roads AL - Mississippi State University



Voodoo Chapter (Kevin F. McDermott) Matching Scholarship
\$2,000 for 1 year - Caleb M Hall - Grandchild of MAJ Wayne Albert, Metairie LA - Louisiana State University



Voodoo Chapter (Kevin F. McDermott) Matching Scholarship
\$2,000 for 1 year - Ainsley A Morgan - Daughter of CW4 Phillip Morgan, Lafayette LA - Louisiana State University



Voodoo Chapter (Phantom Products Inc.) Matching Scholarship
\$2,000 for 1 year - Renee S Nicholson - Grandchild of CPT Donald Nicholson, Mandeville LA - Mississippi State University



Voodoo Chapter Matching Scholarship
\$2,000 for 1 year - Devin S Middleton - Son of LTC Kevin Middleton, Slidell LA - Louisiana State University



Voodoo Chapter Matching Scholarship
\$2,000 for 1 year - Darby R Middleton - Daughter of LTC Kevin Middleton, Slidell LA - University of Southern Mississippi



Voodoo Chapter Matching Scholarship
\$2,000 for 1 year - Hannah Louise Thompson, Ponchatoula, LA - Southeastern Louisiana University



Voodoo Chapter Matching Scholarship
\$2,000 for 1 year - Gabrielle Elaine Bordelon - Daughter of MSG Eugene Bordelon, Prairieville LA - Academy of Interactive Entertainment



Washington-Potomac Chapter Matching Scholarship
\$2,000 for 1 year - Camden A Mounts - Son of CAPT Shelby Mounts, Alexandria VA - The Catholic University of America



Washington-Potomac Chapter Matching Scholarship
\$2,000 for 1 year - Kaylie E Bishop - Daughter of COL Joseph Bishop, Clifton VA - University of Tennessee State University



Washington-Potomac Chapter Matching Scholarship
\$2,000 for 1 year - Gabrielle D Dempsey - Daughter of CPT Horace Dempsey, Washington DC - Old Dominion University



Washington-Potomac Chapter Matching Scholarship
\$2,000 for 1 year - Willow Black - Grandchild of COL Richard Black, Ashburn VA - Stanford University



Washington-Potomac Chapter Matching Scholarship
\$2,000 for 1 year - Nicholas Lee - Son of Mr. Edward Lee, Woodbridge VA - Jacksonville University



Washington-Potomac Chapter Matching Scholarship
\$2,000 for 1 year - Prescott D Farris - Son of COL Prescott Farris, Burke VA - American University



Washington-Potomac Chapter Matching Scholarship
\$2,000 for 1 year - Jessie A Bricker - Daughter of COL Paul Bricker, Clifton VA - Marymount University



Washington-Potomac Chapter Matching Scholarship
\$2,000 for 1 year - Lauren R Kemmer - Daughter of SGM Dusty Kemmer, Severna Park MD - MGH Institute of Health Professions



Washington-Potomac Chapter Matching Scholarship
\$2,000 for 1 year - Jessica M. Avila - Daughter of CW5 Fernando Avila-Gonzalez, Waldorf MD - Columbia University



Washington-Potomac Chapter Matching Scholarship
\$2,000 for 1 year - Olivia R Clary - Daughter of 1SG Christopher Brown, Stafford VA - University of Tennessee Martin



Washington-Potomac Chapter Matching Scholarship
\$2,000 for 1 year - Reagan E Patrick - Daughter of LTC Nathan Patrick, Warrenton VA - University of Richmond



Washington-Potomac Chapter Matching Scholarship
\$2,000 for 1 year - Tyler D Peduzzi - Grandchild of LTC Lawrence Peduzzi, Alexandria VA - University of Georgia

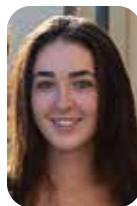

Washington-Potomac Chapter Matching Scholarship
\$2,000 for 1 year - Addison G Parker - Daughter of COL William Parker, Alexandria VA - University of Alabama



Washington-Potomac Chapter Matching Scholarship
\$2,000 for 1 year - Jeffrey (Charlie) C Daood - Grandchild of COL Curt Herrick, Fort Belvoir VA - Creighton University

AAAA Scholarship Foundation Inc. 2023 Awardees



Washington-Potomac Chapter Matching Scholarship
\$2,000 for 1 year - Walker V Wood - Son of COL Jerry Wood, Alexandria VA - Furman University



Washington-Potomac Chapter Matching Scholarship
\$2,000 for 1 year - Mason T. Mounts - Son of CAPT Shelby Mounts, Alexandria VA - Tulane University



Washington-Potomac Chapter Matching Scholarship
\$2,000 for 1 year - Richard Hayden Black - Grandchild of COL Richard Black, Ashburn VA - Duke University



MSG Gary I. Gordon and SFC Randall D. Shugart Memorial Perpetual Scholarship
\$1,500 for 1 year - Shelby Amelia Fricks - Daughter of COL Samuel Fricks, New Brockton AL - Colorado State University



90th Anniversary of Fort Monmouth Perpetual Matching Scholarship
\$1,500 for 1 year - Morgan H Teefy - Daughter of Mr. Dennis Teefy, Havre de Grace MD - West Virginia University



Air Assault Chapter (CW5 George Arzente, Ret.) Perpetual Matching Scholarship
\$1,500 for 1 year - Emily A Miller - Grandchild of CPT Art Jacobs, Brentwood TN - Embry-Riddle Aeronautical University



Air Assault Chapter (CW5 Robert L. Huffman, Ret.) Perpetual Matching Scholarship
\$1,500 for 1 year - Noemi Cerritos Gatto - Daughter of SFC Henry Cerritos Caceres, Fort Campbell KY - Middlebury Institute of International Studies



Air Assault Chapter (Ms. Tameia McCurdy-Talento) Perpetual Matching Scholarship
\$1,500 for 1 year - Krista A Haake - Daughter of LTC Karsten Haake, Clarksville TN - University of New Hampshire



Air Assault Chapter (SFC Andrew McClure) Perpetual Matching Scholarship
\$1,500 for 1 year - Katherine G Clementz - Daughter of LTC Matthew Clementz, Mason OH - The Ohio State University



Lindbergh Chapter Perpetual Matching Scholarship
\$1,500 for 1 year - Rodney D Reichert - Grandchild of LTC David Reichert, Bradenton FL - Northwestern University



Lindbergh Chapter Perpetual Matching Scholarship
\$1,500 for 1 year - Caliandra M Facio - Daughter of CW4 David Facio, Festus MO - Southeast Missouri State University



Lindbergh Chapter Perpetual Matching Scholarship
\$1,500 for 1 year - Olivia G White, O'Fallon, IL - University of Missouri



Mid-Atlantic/Monmouth Chapter (Dean/Kelly) Perpetual Matching Scholarship
\$1,500 for 1 year - Christian Charles McElroy - Son of COL Glen McElroy, Brick NJ - Lesley University



Sikorsky III (Igor Sikorsky) Corporate Perpetual Matching Scholarship
\$1,500 for 1 year - Ashley F Penczynzyn - Daughter of Mr. Alexander Penczynzyn, Wallingford CT - Albertus Magnus College



"The Originals" Cub Club Heritage Matching Scholarship
\$1,500 for 1 year - William R Gunter - Son of COL John Gunter, Pike Road AL - Auburn University



7/17th Cavalry Association (Ruthless Riders) Heritage Matching Scholarship
\$1,500 for 1 year - Ethan D Hanks - Son of MAJ Daniel Hanks, Harker Heights TX - Brigham Young University



COL Charles L. Anderson, Ret Scholarship
\$1,500 for 1 year - Amanda K Cole - Grandchild of LTC Dennis Trigg, San Diego CA - Clemson University



CW5 Lee M. Tutin Memorial Scholarship
\$1,500 for 1 year - Michael T Worch - Grandchild of LTG John Curran, Hudson Oaks TX - Northern Illinois University



Davis Aircraft (Pamela Dukas Memorial) Scholarship
\$1,500 for 1 year - Avery E Ketchmark - Daughter of CW3 Daniel Ketchmark, El Paso TX - University of New Mexico



Frank H. Radspinner Scholarship
\$1,500 for 1 year - Blake D Phillips - Son of CW5 Douglas Phillips, Azle TX - Texas Tech University



Aviation Center Chapter (Amentum Services) Matching Scholarship
\$1,500 for 1 year - Lydia K Johnke - Daughter of COL Bart Johnke, Enterprise AL - University of Alabama



Aviation Center Chapter (Navigator Development Group, Inc.) Matching Scholarship
\$1,500 for 1 year - Chelsey E Trenary - Daughter of CW5 M. Trenary, Leitchfield KY - Auburn University

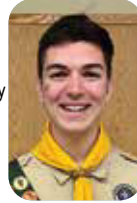

Lindbergh Chapter Matching Scholarship
\$1,500 for 1 year - Daniel Rickmeyer - Grandchild of Mr. Jaros Rickmeyer, St. Louis MO - University of Oklahoma



Lindbergh Chapter Matching Scholarship
\$1,500 for 1 year - Mitchell W Harris - Son of CW5 Bill Harris, Collinsville IL - University Of Health Sciences and Pharmacy



Lindbergh Chapter Matching Scholarship
\$1,500 for 1 year - Alana R Connor - Grandchild of COL Robert Cummings, O Fallon IL - Cedar Crest College



Lindbergh Chapter Matching Scholarship
\$1,500 for 1 year - Jonathan Rickmeyer - Grandchild of Mr. Jaros Rickmeyer, St. Louis MO - University of California, Irvine



Tarheel Chapter (1SG John Hunter Memorial) Matching Scholarship
\$1,500 for 1 year - Grace M Copeland - Daughter of BG Jeffrey Copeland, Raleigh NC - The King's College



Tarheel Chapter (CPT Christopher M. Plummer Memorial) Matching Scholarship
\$1,500 for 1 year - Faith S Almond - Daughter of LTC Mark Almond, Apex NC - Elon University



Tarheel Chapter (CW3 Kevin Hatcher Memorial) Matching Scholarship
\$1,500 for 1 year - John A Anderson - Son of LTC Spencer Anderson, The Woodlands TX - Texas A&M



Tarheel Chapter (CW3 Richard B. James Memorial) Matching Scholarship
\$1,500 for 1 year - Parker F Wilkinson - Daughter of COL Scott Wilkinson, Clarksville TN - Vanderbilt University

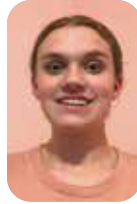

Tarheel Chapter (CW5 James "Freddy" Reeves Memorial) Matching Scholarship
\$1,500 for 1 year - Morgen J Bouma - Daughter of LTC Jeffery Bouma, Leavenworth KS - Wichita State University



Tarheel Chapter (CW5 Randy Watkins Memorial) Matching Scholarship
\$1,500 for 1 year - Garrison M. Brown, New Stanton, PA - University of Pittsburgh

AAAA Scholarship Foundation Inc. 2023 Awardees



Carolyn L. Chapman Memorial Perpetual Scholarship
\$1,000 for 1 year - Breiana N Gray - Daughter of COL Richard Gray, Lincoln NE - Morningside College



COL John J. Stanko, Jr. Memorial Perpetual Scholarship
\$1,000 for 1 year - Benicio T Beatty - Grandchild of CW5 Donald Beatty, Lebanon PA - Brown University

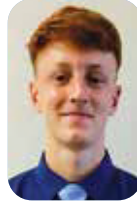

COL Russell Baugh Memorial Perpetual Scholarship
\$1,000 for 1 year - John Robert Azaltovic, Yorktown, VA - Virginia Commonwealth University



Don and Ruth Luce Memorial Perpetual Scholarship
\$1,000 for 1 year - Courtney A Bratt - Daughter of LTC Richard Bratt, Gilbert AZ - The University of Alabama at Birmingham



Families of the Fallen Perpetual Scholarship
\$1,000 for 1 year - Matthew W Debany - son of Richard B Debany (Deceased) - Binghamton University



Families of the Fallen Perpetual Scholarship
\$1,000 for 1 year - Taylor Patterson - daughter of CPT David Alexander Neill (Deceased) - Montana State University



Families of the Fallen Perpetual Scholarship
\$1,000 for 1 year - Wyatt R Paulette - son of LTC James R. Paulette, Jr. (Deceased) - University of New Haven



GEN Hamilton H. Howze Memorial Perpetual Scholarship
\$1,000 for 1 year - Samuel P Fineran - Son of COL Thaddeus Fineran, Lincoln NE - Creighton University



Jane and Wayne Phillips Memorial Perpetual Scholarship
\$1,000 for 1 year - Ray L Carmona - Son of COL Louis Carmona, Rancho Marieta, CA - Northern Illinois University



Aviation Center Chapter Perpetual Matching Scholarship
\$1,000 for 1 year - Brooke M Belden - Daughter of MAJ Kevin Belden, Dothan AL - Auburn University



Aviation Center Chapter Perpetual Matching Scholarship
\$1,000 for 1 year - Abigail C Upchurch - Daughter of CW4 Craig Upchurch, Enterprise AL - University of Tennessee, Knoxville



Colonial Virginia Chapter Perpetual Matching Scholarship
\$1,000 for 1 year - Anna M Stasevich - Grandchild of Ms. Christen Stasevich, Chesapeake VA - Emerson College

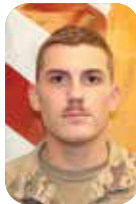

Greater Atlanta Chapter Perpetual Matching Scholarship
\$1,000 for 1 year - Joshua A Lewis - Son of LTC Jerry Lewis, Fayetteville GA - Georgia Institute of Technology



Lindbergh Chapter (Past Presidents) Perpetual Matching Scholarship
\$1,000 for 1 year - Bear M Reichert - Grandchild of LTC David Reichert, Bradenton FL - University of New Mexico



Mid-Atlantic Chapter (244th Expeditionary Combat Aviation Brigade) Perpetual Matching Scholarship
\$1,000 for 1 year - Jaelynd N Edwards - Daughter of MG Joseph Edwards, Conroe TX - Lone Star College- Montgomery

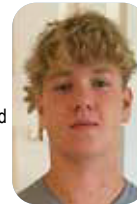

Mid-Atlantic Chapter (29th Combat Aviation Brigade) Perpetual Matching Scholarship
\$1,000 for 1 year - John A Kilby - Son of MAJ John Kilby, Rising Sun MD - Baylor University



Mid-Atlantic/Monmouth Chapter (Apblett/Gobel Memorial)
\$1,000 for 1 year - Kristi R Gallagher - Grandchild of COL John Gallagher, Havre De Grace MD - Converse University



Mid-Atlantic/Monmouth Chapter (COL James E. Young) Perpetual Matching Scholarship
\$1,000 for 1 year - Hannah F Mains - Grandchild of Sgt Fredric Robins, Tenafly NJ - University of Miami



Mid-Atlantic/Monmouth Chapter (Hogelin/O'Donnell) Perpetual Matching Scholarship
\$1,000 for 1 year - Payton E Hawk - Bloomsbury, NJ - George Mason University



Mid-Atlantic/Monmouth Chapter (MAJ R. Kahl-Winter) Perpetual Matching Scholarship
\$1,000 for 1 year - Aidan C Hermann - Grandchild of CW5 Keith Harris, Bel Air MD - Loyola University Maryland



North Texas Chapter (Edwin "Ed" A. Link Memorial) Perpetual Matching Scholarship
\$1,000 for 1 year - Sydney G Corcoran - Grandchild of LTC Fred Bagley, Little Elm TX - Texas A&M

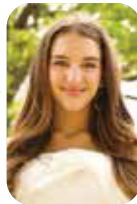

North Texas Chapter (George H. Schultz Memorial) Matching Scholarship
\$1,000 for 1 year - Jordyn R Price - Grandchild of CW2 Arthur Price, Crowley TX - University of North Texas



North Texas Chapter (Lawrence "Larry" D. Bell Memorial) Perpetual Matching Scholarship
\$1,000 for 1 year - Tommy Thompson - Son of CSM James Hall, Dallas TX - Rice University



North Texas Chapter (LTG Bob Williams Memorial) Perpetual Matching Scholarship
\$1,000 for 1 year - Rebekah L Boisvert - Grandchild of 1stLT Mark Byrd, Dallas TX - University of Texas



North Texas Chapter (Mike Kawa Memorial) Perpetual Matching Scholarship
\$1,000 for 1 year - Maci L White - Grandchild of LTC Thomas Smith, Heath TX - Dallas Baptist University



North Texas Chapter (Red River 44 Memorial) Perpetual Matching Scholarship
\$1,000 for 1 year - Keziah D Hanna - Daughter of LTC Chris Hanna, Waxahachie TX - Texas Christian University



Stonewall Jackson Chapter (SSG Darryl D. Booker) Perpetual Matching Scholarship
\$1,000 for 1 year - Elizabeth H Woodward - Grandchild of COL James Holden, Richmond VA - University of Virginia



Volunteer Chapter (1LT Thomas Williams, Jr.) Perpetual Matching Scholarship
\$1,000 for 1 year - Mackenzie K Watson, Powell, TN - Harding University



Volunteer Chapter (CPT Marcus Alford Memorial) Perpetual Matching Scholarship
\$1,000 for 1 year - Paxton C Rigdon - Son of LTC John Rigdon, Murfreesboro TN - Belmont University



Volunteer Chapter (CW2 Billie Jean Grinder Memorial) Perpetual Matching Scholarship
\$1,000 for 1 year - Taylor Shea Arnold - Daughter of SGT Joshua Travis, Trenton TN - Middle Tennessee State University



Volunteer Chapter (CW3 Tim Flanigan Memorial) Perpetual Matching Scholarship
\$1,000 for 1 year - Peter M Minkoff - Son of Mr. Bill Minkoff, Nashville TN - University of Chicago



Volunteer Chapter (CW4 Dan Cole Memorial) Perpetual Matching Scholarship
\$1,000 for 1 year - Nicholas N Rogers - Son of MAJ Patrick Rogers, Maryville TN - Liberty University

AAAA Scholarship Foundation Inc. 2023 Awardees



Art and Dotty Kesten AAPI Corporate Perpetual Matching Scholarship
\$1,000 for 1 year - Lily C Barnes - Daughter of MSG Cory Barnes, Sequim WA - Western Washington University



Bannister Enterprises Corporate Perpetual Matching Scholarship
\$1,000 for 1 year - Ace Brown, Austin, TX - University of Texas - Austin



Donaldson Company, Inc., Aerospace & Defense Corporate Perpetual Matching Scholarship
\$1,000 for 1 year - Daniel C Boyce - Son of Mr. Mark Boyce, Chesterfield MO - Pensacola Christian College



DynCorp International Corporate Perpetual Matching Scholarship
\$1,000 for 1 year - Emma S Howard - Daughter of 1SG William Howard, Eastchester NY - University of Florida



Meggitt Defense Systems Corporate Perpetual Matching Scholarship
\$1,000 for 1 year - Bethany G Journigan - Daughter of CSM James Journigan, Wahiawa HI - Lees Mc-Rae College



Northrop Grumman Corporate Perpetual Matching Scholarship
\$1,000 for 1 year - Conrad J. Martin - Son of LTC Phillip Martin, Madison AL - Northwestern University



Peduzzi Associates Limited Perpetual Matching Scholarship
\$1,000 for 1 year - Gavin Sleigh - Son of Mr. James Sleigh, Palm City FL - University of Florida OR Sante Fe College



Robertson Research Group, Inc. Corporate Perpetual Matching Scholarship
\$1,000 for 1 year - Ashley Melynky - Daughter of COL Richard Melynky, West Point NY - James Madison University



The WO1 Arthur F. Chaney Memorial Corporate Perpetual Matching Scholarship
\$1,000 for 1 year - Sarah D Cole - Grandchild of LTC Dennis Trigg, San Diego CA - University of Pittsburgh

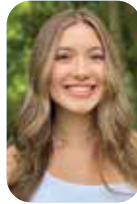

Vencore, Inc. Corporate Perpetual Matching Scholarship
\$1,000 for 1 year - Blakely H Wilkinson - Daughter of COL Scott Wilkinson, Clarksville TN - Vanderbilt University



Vertex Aerospace LLC Corporate Perpetual Matching Scholarship
\$1,000 for 1 year - Sara C Milio - Daughter of LTC Michael Milio, Annapolis MD - University of Virginia



190th Assault Helicopter Company (Spartans) Heritage Matching Scholarship
\$1,000 for 1 year - Jonah M Mrochek - Grandchild of COL John Marcy, South Pasadena FL - Miami University



Mike Novosel Dustoff Association Heritage Matching Scholarship
\$1,000 for 1 year - Meagan V White - Daughter of LTC David White, Johns Island SC - Davidson College



Otter-Caribou Heritage Matching Scholarship
\$1,000 for 1 year - Nicholas Turnage - Grandchild of COL Larry Turnage, Dothan AL - Immaculata University



Otter-Caribou Heritage Matching Scholarship
\$1,000 for 1 year - Jonathan C Marshall - Grandchild of Mrs. Harriet Marshall, Matthews NC - Covenant College



Otter-Caribou Heritage Matching Scholarship
\$1,000 for 1 year - Aislyn G Beauregard, Weatherford, TX - Texas Tech University



Otter-Caribou Heritage Matching Scholarship
\$1,000 for 1 year - Andrea E Westcott - Grandchild of Mr. Thomas Westcott, Fairmont MN - Minnesota State University Mankato



Otter-Caribou Heritage Matching Scholarship
\$1,000 for 1 year - Sheridan R Bredehoeft - Grandchild of CAPT Fred Bredehoeft, Independence MO - Kansas State University



Otter-Caribou Heritage Matching Scholarship
\$1,000 for 1 year - Timothy D Marshall - Grandchild of Mrs. Harriet Marshall, Matthews NC - Covenant College

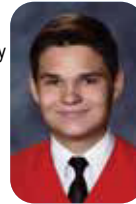

Otter-Caribou Heritage Matching Scholarship
\$1,000 for 1 year - Matthew L Montgomery, Yukon, OK - Oklahoma State University



TCAA (Transportation Corps Aviation Association) Heritage Matching Scholarship
\$1,000 for 1 year - Hannah M Hamontree - Daughter of LTC George Hamontree, Riverview FL - Old Dominion University



The Army Aviation Heritage Foundation Sky Soldiers Matching Scholarship
\$1,000 for 1 year - Cody T Lloyd - Son of COL Howard Lloyd, Fredericksburg PA - The Pennsylvania State University



The OV-1 Mohawk Association Heritage Matching Scholarship
\$1,000 for 1 year - Lily Ann M Keutzer - Grandchild of SPC Kendall Keutzer, Arlington IL - Southern Illinois University



Vietnam Helicopter Pilots Association of Florida (VHPA) Heritage Matching Scholarship
\$1,000 for 1 year - Tess N Hatchell - Grandchild of MAJ Mike Hatchell, Albuquerque NM - Southern Methodist University



1LT Kathryn M. Bailey Memorial Scholarship
\$1,000 for 1 year - Andrew J Crane - Grandchild of 1LT Thomas Damson, Mobile AL - Auburn University



1LT Kathryn M. Bailey Memorial Scholarship
\$1,000 for 1 year - Nathaniel J Seal - Sibling of Mr. Conor Seal, Gurnee IL - Florida Gulf Coast University



COL Harry W. Townsend, Ret. Memorial Scholarship
\$1,000 for 1 year - Maggi K Flood - Daughter of CPT Roberta Flood, Prescott AZ - Embry-Riddle Aeronautical University



CW2 Keith E. Cedras Memorial Scholarship
\$1,000 for 1 year - Dylan Richardson, Santa Barbara, CA - Whitworth University



CW3 Stephen A. Hansen Memorial Scholarship
\$1,000 for 1 year - Joshua S McClure, Tampa, FL - Embry-Riddle Aeronautical University



CW4 Jimmy B. Johnston & Family Scholarship
\$1,000 for 1 year - Brittany L Perez - Daughter of SGT Manuel Perez, Robstown TX - Texas A&M University Corpus Christi

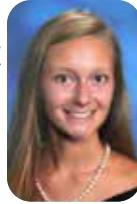

Dianne Stephenson Memorial Scholarship
\$1,000 for 1 year - Elliot A Yood - Grandchild of LTC Richard Yood, Tallahassee FL - University of Georgia



LTC Thomas F. and Ann Y. McNamara Scholarship
\$1,000 for 1 year - Connor M Johnson - Grandchild of Capt William Johnson, Lake Jackson TX - Georgia Institute of Technology

AAAA Scholarship Foundation Inc. 2023 Awardees



MG Andy and Artie Anderson Scholarship
\$1,000 for 1 year - Emily A Mazingo - Daughter of COL Phillip Mazingo, Fort Belvoir VA - Auburn University



Sandra Ann Emerson Memorial Scholarship
\$1,000 for 1 year - Hannah E Edmonds - Grandchild of LTC James (Joe) Emerson, Harpers Ferry IA - Mississippi State



Susan Yellen Memorial Scholarship
\$1,000 for 1 year - Olivia C Crump - Daughter of CW5 Matthew Crump, Dothan AL - Auburn University



Terry and Bonnie Reinger Scholarship
\$1,000 for 1 year - Alyson Aida Grow, Haltom City, TX - Stephen F. Austin State University



Air Assault Chapter Matching Scholarship
\$1,000 for 1 year - Caleb A Hankemeier - Son of CW4 Adam Hankemeier, Clarksville TN - University of Tennessee



Air Assault Chapter Matching Scholarship
\$1,000 for 1 year - Dilynn H Riddle - Daughter of MSG Joseph Riddle, Clarksville TN - University of Colorado Boulder

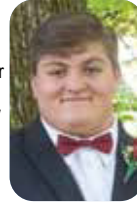

Air Assault Chapter Matching Scholarship
\$1,000 for 1 year - Tristan J Petit - Son of Ms. Carolyn Petit, Pleasant View TN - Lindsey Wilson College



Air Assault Chapter Matching Scholarship
\$1,000 for 1 year - Kieran J Wilson - Son of CPT John Wilson, Statesville NC - Anderson University



Air Assault Chapter Matching Scholarship
\$1,000 for 1 year - Adam William Quinn, Fort Campbell, KY - Colorado State University



Air Assault Chapter Matching Scholarship
\$1,000 for 1 year - Grace M. Howell - Daughter of CW5 Thomas Clark, Clarksville TN - University of Tennessee



Air Assault Chapter Matching Scholarship
\$1,000 for 1 year - Kayla M. Worthy - Daughter of MSG Curtis Worthy, Clarksville TN - Western Kentucky University



Aviation Center Chapter (Aero-One Aviation) Matching Scholarship
\$1,000 for 1 year - Jacob R Upchurch - Son of CW4 Craig Upchurch, Enterprise AL - Auburn University



Aviation Center Chapter (AVT Simulation) Matching Scholarship
\$1,000 for 1 year - Gabriela N Perez - Daughter of SGT Francisco Perez, Enterprise AL - Troy University



Aviation Center Chapter (Bell Helicopter) Matching Scholarship
\$1,000 for 1 year - Ashleigh M Tarutani - Daughter of LTC Jerome Tarutani, Enterprise AL - Auburn University



Aviation Center Chapter (General Atomics Aeronautical Systems, Inc.) Matching Scholarship
\$1,000 for 1 year - Meredith K Lamb - Grandchild of CW4 Clarke Barber, Enterprise AL - Washington State University



Aviation Center Chapter (M1 Support Services) Matching Scholarship
\$1,000 for 1 year - Joseph M Tarlavsky - Son of LTC Donald Kirk, Enterprise AL - Hamilton College

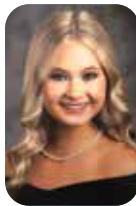

Aviation Center Chapter (Mass Virtual) Matching Scholarship
\$1,000 for 1 year - Jade D Belden - Daughter of MAJ Kevin Belden, Dothan AL - Auburn University



Aviation Center Chapter (Mass Virtual) Matching Scholarship
\$1,000 for 1 year - Jackson R Sneed - Grandchild of COL Robert Enyeart, Ozark AL - Auburn University



Aviation Center Chapter (Northrop Grumman) Matching Scholarship
\$1,000 for 1 year - Eileen D Majka - Daughter of CW3 Darick Majka, Enterprise AL - University of Saint Augustine for Health Sciences



Aviation Center Chapter (Northrop Grumman) Matching Scholarship
\$1,000 for 1 year - Ryan A Brown, Enterprise, AL - Texas A&M University



Aviation Center Chapter (Projects Unlimited) Matching Scholarship
\$1,000 for 1 year - John A Corbin - Grandchild of CW4 John Edmunds, Enterprise AL - Wallace Community College

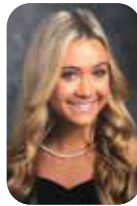

Aviation Center Chapter (Sikorsky a Lockheed Martin Company) Matching Scholarship
\$1,000 for 1 year - Chloe E Belden - Daughter of MAJ Kevin Belden, Dothan AL - Auburn University



Aviation Center Chapter (The Boeing Company) Matching Scholarship
\$1,000 for 1 year - Emily A Dellavecchia - Daughter of CW3 Joshua Della Vecchia, Enterprise AL - Troy University



Aviation Center Chapter Matching Scholarship
\$1,000 for 1 year - Samantha C Cottrill - Daughter of CW5 Chris Cottrill, Mechanicsburg PA - Messiah College



Aviation Center Chapter Matching Scholarship
\$1,000 for 1 year - Noreen E Van Loan - Spouse of CW5 Paul Van Loan, Enterprise AL - Troy University



Aviation Center Chapter Matching Scholarship
\$1,000 for 1 year - Marlee L Schaare - Spouse of WO1 Robert Schaare, Fort Rucker AL - Arizona State University, Tempe Campus

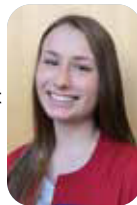

Badger Chapter Matching Scholarship
\$1,000 for 1 year - Kirsten M Southworth - Daughter of LTC Kurt Southworth, Reedsburg WI - Viterbo University



Badger Chapter Matching Scholarship
\$1,000 for 1 year - Thomas J Kleinheinz - Son of MSG Troy Kleinheinz, Middleton WI - Arizona State University



Colonial Virginia Chapter Matching Scholarship
\$1,000 for 1 year - Catherine Nicole Byars - Grandchild of LTC Harold Byars, Newport News VA - Texas A&M University

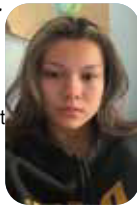

Colonial Virginia Chapter Matching Scholarship
\$1,000 for 1 year - McKenzie N Meyer - Daughter of LTC David Meyer, Yorktown VA - Virginia Commonwealth University



Cowboy Chapter (Dustoff) Matching Scholarship
\$1,000 for 1 year - Joseph J Pavelites - Son of Mr. Joseph Pavelites, Fayetteville NC - University of South Alabama



Cowboy Chapter (Fallen Cowboys Memorial) Matching Scholarship
\$1,000 for 1 year - Kamryn Pestel - Grandchild of CW4 Terrence Pestel, Lombard IL - Virginia Polytechnic Institute and State University

AAAA Scholarship Foundation Inc. 2023 Awardees



Cowboy Chapter (Outriders) Matching Scholarship
\$1,000 for 1 year - Garrison D Brown - Son of LTC Matt Brown, College Station TX - Texas A&M University



Delaware Valley Chapter (Frank Piasecki Memorial) Matching Scholarship
\$1,000 for 1 year - Karlos K Chanquin - Son of MSG Nelson Chanquin, Columbus NJ - University of Kansas



Delaware Valley Chapter (Frank Piasecki Memorial) Matching Scholarship
\$1,000 for 1 year - Samuel Burke Debany - Son of COL Richard Debany, Springfield PA - Cabrini University



Delaware Valley Chapter (Frank Piasecki Memorial) Matching Scholarship
\$1,000 for 1 year - Isabel M Coupe - Grandchild of LTC Arthur Coupe, Wilmington DE - Gettysburg College



Delaware Valley Chapter (Fred Bergner Memorial) Matching Scholarship
\$1,000 for 1 year - Paula Brown - Sibling of Mr. Garrison Brown, New Stanton PA - University of Pittsburgh



Delaware Valley Chapter (Fred Bergner Memorial) Matching Scholarship
\$1,000 for 1 year - Maria L Gross - Daughter of LTC Michael Gross, Lebanon PA - Lafayette College



Delaware Valley Chapter (Fred Bergner Memorial) Matching Scholarship
\$1,000 for 1 year - Sophia Bohl - Daughter of CPT Darlene Bohl, Billings MT - Montana State University



Delaware Valley Chapter (Harry McGinness Memorial) Matching Scholarship
\$1,000 for 1 year - Kai Mills - Son of LTC Casey Mills, Ft Benning GA - Lindenwood University



Delaware Valley Chapter (Harry McGinness Memorial) Matching Scholarship
\$1,000 for 1 year - Morgan R Werner - Daughter of MAJ Marc Werner, Cape Coral FL - Butler University



Delaware Valley Chapter (Harry McGinness Memorial) Matching Scholarship
\$1,000 for 1 year - Brooke Messa - Grandchild of CW4 David Messa, Gulfport MS - Auburn University



Delaware Valley Chapter (Harry McGinness Memorial) Matching Scholarship
\$1,000 for 1 year - Sarah E Freeman - Grandchild of 1LT Thomas Damsom, Mobile AL - Auburn University



Don Munsch-Jimmy Doolittle Chapter Matching Scholarship
\$1,000 for 1 year - Kyle Landers - Son of LTC John Landers, Columbia SC - The University of Alabama School of Medicine



Gold Standard Chapter (The Extortion 17 Aircrew Memorial) Matching Scholarship
\$1,000 for 1 year - Josephine E Hagan - Daughter of 1SG Terry Timmons, Louisville KY - University of Kentucky



Gold Standard Chapter Matching Scholarship
\$1,000 for 1 year - Karleigh A Milio - Daughter of LTC Michael Milio, Annapolis MD - UMass Amherst



Griffin Chapter (John "Jay" Brainard III Memorial) Matching Scholarship
\$1,000 for 1 year - Kennedy J Kohrs - Daughter of CW4 Chad Kohrs, APO AE - Iowa State University



Griffin Chapter (John C. Pratt Memorial) Matching Scholarship
\$1,000 for 1 year - Kylie R Broussard - Daughter of CW4 Jeffrey Letort, Vancleave MS - Mississippi State University



Johnny O Cluster Chapter Matching Scholarship
\$1,000 for 1 year - Christopher D Gaston - Grandchild of Capt Leonard Whiteing, Omaha NE - Purdue University

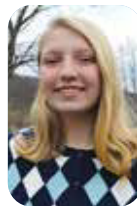

Keystone Chapter (Aircrafters Inc.) Matching Scholarship
\$1,000 for 1 year - Lily C Palfrey - Daughter of 1SG Frank Palfrey, Indiana PA - Indiana University of Pennsylvania



Keystone Chapter (Aircrafters Inc.) Matching Scholarship
\$1,000 for 1 year - Lillian E Gross - Daughter of LTC Michael Gross, Lebanon PA - University of Pittsburgh



Keystone Chapter (Ernest D. Carlson Sr. Memorial) Matching Scholarship
\$1,000 for 1 year - Jackson Daniel Gross - Son of LTC Daniel Gross, State College PA - Penn State University



Keystone Chapter (Gun 23 Memorial) Matching Scholarship
\$1,000 for 1 year - Bailey A Lutz - Son of LTC Randy Lutz, Dillsburg PA - Pennsylvania State University



Keystone Chapter (Keystone Armory) Matching Scholarship
\$1,000 for 1 year - Nicole K Glaus - Spouse of SGT Stephen Glaus, Elizabethtown PA - Pennsylvania College of Health Science



Keystone Chapter (Keystone Shooting Center) Matching Scholarship
\$1,000 for 1 year - Emmanuel D Beatty - Grandchild of CW5 Donald Beatty, Lebanon PA - DeSales University



Keystone Chapter (Riegler, Shienvold and Associates) Matching Scholarship
\$1,000 for 1 year - Gillian N Madeira - Daughter of CW4 Frank Madeira, Lebanon PA - Lebanon Valley College



Keystone Chapter (SSG Ernest C. Carlson Memorial) Matching Scholarship
\$1,000 for 1 year - Romello D. Wilson - Sibling of CPT Craig Robbins, Easton PA - Louisiana State University



MacArthur Chapter (COL Charles J. Humphries) Matching Scholarship
\$1,000 for 1 year - Rachel A Loyst - Daughter of Mrs. Louise Loyst, Lake Grove NY - Renaissance School of Medicine



MacArthur Chapter (COL Vincent J. Albanese) Matching Scholarship
\$1,000 for 1 year - Megan E Wojciechowski - Grandchild of CW4 Michael Howard, Smithville TN - Kettering University



MacArthur Chapter (COL William Zimmerman) Matching Scholarship
\$1,000 for 1 year - Jonathan D Craig - Son of CW3 Kevin Craig, Medford NY - Stony Brook University



MacArthur Chapter (Lyan Fung) Matching Scholarship
\$1,000 for 1 year - Matthew A Stoddart - Grandchild of Mr. Karl Zacek, Holbrook NY - Stonybrook University



Minuteman Chapter (CW3 Scotty Landis Memorial) Matching Scholarship
\$1,000 for 1 year - Emily V Belmont - Daughter of MAJ Jonathan Belmont, Concord MA - University of Massachusetts Amherst



Minuteman Chapter (CW3 Terry Knight Memorial) Matching Scholarship
\$1,000 for 1 year - Kevin A Arellano - Son of SSG Guido Arellano, Belton TX - The University of Texas at Austin



Minuteman Chapter (CW5 Phil Reeves Memorial) Matching Scholarship
\$1,000 for 1 year - William D Johnson - Grandchild of Capt William Johnson, Lake Jackson TX - Texas A&M University

AAAA Scholarship Foundation Inc. 2023 Awardees



Mount Rainier Chapter Matching Scholarship
\$1,000 for 1 year - Mia A. Ludwig - Grandchild of LTC Steven Ludwig, Mill Creek WA - University of California Los Angeles



Mount Rainier Chapter Matching Scholarship
\$1,000 for 1 year - Victoria M Prouty, Del Mar, CA - San Diego State University



North Star Chapter Matching Scholarship
\$1,000 for 1 year - Luke Johnson, Two Harbors, MN - Michigan Technological University



North Star Chapter Matching Scholarship
\$1,000 for 1 year - Grace A Crigler - Daughter of CW3 James Crigler, Winona MN - University of Wisconsin-Stout



North Texas Chapter (Sidney Achee "The Originals") Matching Scholarship
\$1,000 for 1 year - Raymond M Gehrig, Roanoke, TX - University of Oregon



North Texas Chapter Matching Scholarship
\$1,000 for 1 year - Blake E Campbell - Grandchild of CW4 William Campbell, Denton TX - Saint Mary's University of Minnesota



North Texas Chapter Matching Scholarship
\$1,000 for 1 year - Jonathon L Robertson - Grandchild of LTC Jim Wingate, Fort Worth TX - University of South Carolina



North Texas Chapter Matching Scholarship
\$1,000 for 1 year - Jackson C Charles - Grandchild of LTC Terrance Reiningor, North Richland Hills TX - Texas A&M University



North Texas Chapter Matching Scholarship
\$1,000 for 1 year - Riley B Mears - Daughter of Mr. Steve Mears, Grand Prairie TX - University of St Augustine for Health Sciences



North Texas Chapter Matching Scholarship
\$1,000 for 1 year - Joshua D. Robertson - Grandchild of LTC Jim Wingate, Fort Worth TX - Texas A&M University



North Texas Chapter Matching Scholarship
\$1,000 for 1 year - Ethan Crofts, Weatherford, TX - University of Kansas



North Texas Chapter Matching Scholarship
\$1,000 for 1 year - Harrison P Hamre - Son of 1LT Jason Hamre, Flower Mound TX - University of Kansas



Northern Lights Chapter Matching Scholarship
\$1,000 for 1 year - Savanna L Collier - Daughter of CW4 Eric Collier, North Pole AK - University of Alaska Anchorage



Phantom Corps Chapter Matching Scholarship
\$1,000 for 1 year - Nylah R Yuille - Daughter of Mr. James Yuille, Harker Heights TX - Liberty University



Phantom Corps Chapter Matching Scholarship
\$1,000 for 1 year - Alyssa A Church - Daughter of SGM Randy Church, Kempner TX - Tarleton State University



Prairie Soldier Chapter Matching Scholarship
\$1,000 for 1 year - John M. Bequette - Son of COL Bryan Bequette, Nebraska City NE - University of Nebraska Lincoln



Prairie Soldier Chapter Matching Scholarship
\$1,000 for 1 year - Kayla E Coonfare - Grandchild of Capt Leonard Whiteing, Omaha NE - Appalachian State University



Savannah Chapter Matching Scholarship
\$1,000 for 1 year - Libbi R Wilsher - Daughter of LTC Arin Wilsher, Murfreesboro TN - University of Tennessee



1LT Joel R. Graft Memorial Scholarship
\$1,000 for 1 year - Thomas D Sparks, Lake Havasu City, AZ - Lionel University



AAAA National Cowboy Top Chapter Scholarship
\$1,000 for 1 year - Paige K Thamer - Grandchild of CW4 Keith Thamer, Carlsbad CA - Indiana Institute of Technology



AAAA National Mount Rainier Chapter Top Chapter Scholarship
\$1,000 for 1 year - Anthony J Davis, DuPont, WA - University of Washington



AAAA National Old Tucson Top Chapter Scholarship
\$1,000 for 1 year - Madeleine M Luther - Daughter of CW4 Matt Luther, Madeira OH - The University of Alabama



AAAA Washington Potomac Top Chapter Scholarship
\$1,000 for 1 year - Sarah M Brundage - Daughter of CW5 Tim Brundage, Purcellville VA - Liberty University



AAAA Life Member (BG Jack W. Hemingway) Memorial Scholarship
\$1,000 for 1 year - Elizabeth K Swaine - Daughter of SGM David Swaine, Madison AL - Yale University



AAAA Life Member (COL Albert L. Fournier) Memorial Scholarship
\$1,000 for 1 year - Forrest H Woodward - Grandchild of COL James Holden, Richmond VA - United States Naval Academy



AAAA Life Member (COL Arthur W. Buswell) Memorial Scholarship
\$1,000 for 1 year - Teaghan M Harris - Daughter of Mr. Roy Harris, Meridianville AL - King University



AAAA Life Member (COL Byron P. Howlett, Jr.) Memorial Scholarship
\$1,000 for 1 year - Molly E Soden - Grandchild of CW3 Troy Wise, Homer AK - St. Mary's College of Maryland



AAAA Life Member (COL Charles R. Jones) Memorial Scholarship
\$1,000 for 1 year - Winter R Hansen - Grandchild of Capt Michael Law, New Braunfels TX - Brigham Young University



AAAA Life Member (CPT William R. Stuyvesant) Memorial Scholarship
\$1,000 for 1 year - Victoria C Cole - Grandchild of LTC Dennis Trigg, San Diego CA - William and Mary



AAAA Life Member (CW4 Donald R. Joyce) Memorial Scholarship
\$1,000 for 1 year - Kyle J Desrosiers - Son of MAJ John Desrosiers, San Clemente CA - California Polytechnic State University



AAAA Life Member (CW4 Jimmy B. Johnston) Memorial Scholarship
\$1,000 for 1 year - Daisy L Attaway - Daughter of MAJ James Attaway, Nacogdoches TX - University of Texas - Austin



AAAA Life Member (CW4 John R. Hedges) Memorial Scholarship
\$1,000 for 1 year - Patrick M Holt - Son of CW2 Mark Holt, Aurora IL - University of Illinois at Chicago

AAAA Scholarship Foundation Inc. 2023 Awardees



AAAA Life Member (Edward J. Balmos) Memorial Scholarship
\$1,000 for 1 year - Madison B Jones - Daughter of LTC Darrell Jones, Fayetteville NC - Clemson University



AAAA Life Member (Kenneth C. Eaton) Memorial Scholarship
\$1,000 for 1 year - Hunter T Mason - Son of Mr. Richard Mason, Madison AL - Taylor University



AAAA Life Member (LTC Adolf H. Grimm) Memorial Scholarship
\$1,000 for 1 year - Allison P Anderson - Daughter of LTC Spencer Anderson, The Woodlands TX - Texas A&M University



AAAA Life Member (LTC William N. Eckert) Memorial Scholarship
\$1,000 for 1 year - Mikaila M Dinkins - Grandchild of LTC Eugene Gesele, Madison AL - University of Kentucky



AAAA Life Member (LTG Jack V. Mackmull) Memorial Scholarship
\$1,000 for 1 year - Maire I LaRowe - Daughter of COL Major LaRowe, Center Sandwich NH - Georgetown University



AAAA Life Member (MG Carl H. McNair, Jr.) Memorial Scholarship
\$1,000 for 1 year - Jadyn A Kent - Grandchild of LTC Donald Kent, Glen Ellyn IL - University of South Carolina



AAAA Life Member (Mr. Allen E. Jants) Memorial Scholarship
\$1,000 for 1 year - Bennett W Bridges - Son of COL David Bridges, South Burlington VT - University of Vermont



Airbus Dinner Concert Scholarship
\$1,000 for 1 year - Lucy A Hillestad - Grandchild of Mr. Ronald Swanson, Shawnee KS - University of Central Missouri



Airbus Dinner Concert Scholarship
\$1,000 for 1 year - Catlyn C Williams - Grandchild of LTCol John Caruso, Indian Shores FL - George Mason



Airbus Dinner Concert Scholarship
\$1,000 for 1 year - Ivy J Hoffman - Grandchild of CW2 Dwight Hoffman, Milton FL - Swarthmore College



AIRtec Dinner Concert Scholarship
\$1,000 for 1 year - Jake H Harbour - Son of Mr. John Harbour, Huntsville AL - Auburn University



AIRtec Dinner Concert Scholarship
\$1,000 for 1 year - Madison N Borders - Grandchild of CW2 Lyle Borders, Longmont CO - University of Kansas



AIRtec Dinner Concert Scholarship
\$1,000 for 1 year - Michael L Nearn - Son of CW4 Michael Nearn, Fayetteville NC - North Carolina Agricultural and Technical



Amentum Dinner Concert Scholarship
\$1,000 for 1 year - Samantha J Unruh - Grandchild of CW2 Clinton Unruh, Dalhart TX - West Texas A&M University



Amentum Dinner Concert Scholarship
\$1,000 for 1 year - Christian N Pettigrew, Colorado Springs, CO - Colorado State University



Amentum Dinner Concert Scholarship
\$1,000 for 1 year - Natalia Elise Garza - Daughter of Mr. Manuel Garza, San Diego CA - Franklin and Marshall



Amentum Dinner Concert Scholarship
\$1,000 for 1 year - Desiree M Barron - Grandchild of CW3 Joseph Riley, Slana AK - Idaho State University



Amentum Dinner Concert Scholarship
\$1,000 for 1 year - Kate Whitefield - Grandchild of CW2 Albert Fritz, Overland Park KS - Belmont University



Bell Dinner Concert Scholarship
\$1,000 for 1 year - Catherine A Schwendimann - Daughter of LTC Chris Schwendimann, Spartanburg SC - University of North Carolina Chapel Hill



Bell Dinner Concert Scholarship
\$1,000 for 1 year - Ian C Osborn, Palm City, FL - Florida Institute of Technology



Bell Dinner Concert Scholarship
\$1,000 for 1 year - Joslyn K MacDonald - Grandchild of 1LT Rex Gooch, Kerrville TX - Indiana University



Bell Dinner Concert Scholarship
\$1,000 for 1 year - Hillary R Heitz - Grandchild of CW2 William Riley, Estero FL - University of Wisconsin Madison

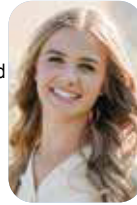

Bell Dinner Concert Scholarship
\$1,000 for 1 year - Katherine M Anderson - Daughter of LTC Spencer Anderson, The Woodlands TX - Texas A&M



DigiFlight, Inc. Dinner Concert Scholarship
\$1,000 for 1 year - Brianna N White - Daughter of Ms. Katherine White, Huntsville AL - Eckerd College



DigiFlight, Inc. Dinner Concert Scholarship
\$1,000 for 1 year - Lucy Sinclair - Grandchild of BG E.J. Sinclair, Huntsville AL - University of Alabama



GE Aerospace Dinner Concert Scholarship
\$1,000 for 1 year - Brianna L Riggers - Spouse of SFC Ryan Thompson, San Tan Valley AZ - Arizona State University



GE Aerospace Dinner Concert Scholarship
\$1,000 for 1 year - Benjamin T Hansen - Grandchild of Capt Michael Law, New Braunfels TX - Brigham Young University



GE Aerospace Dinner Concert Scholarship
\$1,000 for 1 year - Katherine E Hayden - Grandchild of LTC William Pohlmann, Madison AL - Auburn University



Science & Engineering Services, Inc. Dinner Concert Scholarship
\$1,000 for 1 year - Brady S Jackson - Grandchild of CAPT Gary Roush, Painted Post NY - Elon University



Science & Engineering Services, Inc. Dinner Concert Scholarship
\$1,000 for 1 year - Erich R Then - Son of COL Erich Then, Hendersonville NC - University of California San Diego



Science & Engineering Services, Inc. Dinner Concert Scholarship
\$1,000 for 1 year - Allee J Foley - Grandchild of CPT James Fink, Tucker GA - The University of North Georgia



Sikorsky, a Lockheed Martin Co. Dinner Concert Scholarship
\$1,000 for 1 year - Ella J Lampe - Daughter of COL Charles Lampe, Grimes IA - University of Iowa

AAAA Scholarship Foundation Inc. 2023 Awardees



Sikorsky, a Lockheed Martin Co. Dinner Concert Scholarship
\$1,000 for 1 year - Jake E Genger - Son of LTC Noah Genger, Clancy MT - Montana State University



Sikorsky, a Lockheed Martin Co. Dinner Concert Scholarship
\$1,000 for 1 year - Maya Badhwar - Grandchild of CW4 John Clem, Marysville OH - The Ohio State University



Strata-G Solutions, LLC Dinner Concert Scholarship
\$1,000 for 1 year - Lauren M Morgan - Daughter of COL John Michael Morgan, Pinehurst NC - Liberty University



Systems Studies & Simulation, Inc AAAASFI Dinner Concert Scholarship
\$1,000 for 1 year - Christine Schueckler - Grandchild of CW2 James Schueckler, Le Roy NY - University of Virginia



Systems Studies & Simulation, Inc AAAASFI Dinner Concert Scholarship
\$1,000 for 1 year - Mary Jane Erskin - Daughter of CW3 Jerome Erskin, Henrico VA - University of Virginia



Systems Studies & Simulation, Inc AAAASFI Dinner Concert Scholarship
\$1,000 for 1 year - Christopher W Martell - Son of CW4 Wayne Martell, Quinton VA - American University



Systems Studies & Simulation, Inc AAAASFI Dinner Concert Scholarship
\$1,000 for 1 year - Micah A Crum, Lauderdale, MS - University of Southern Mississippi



Systems Studies & Simulation, Inc AAAASFI Dinner Concert Scholarship
\$1,000 for 1 year - Jack P Flood - Son of CPT Roberta Flood, Prescott AZ - Auburn University



Systems Studies & Simulation, Inc AAAASFI Dinner Concert Scholarship
\$1,000 for 1 year - Cade A Hertzendorf - Son of COL Michael Hertzendorf, Bonita Springs FL - Rochester Institute of Technology



Systems Studies & Simulation, Inc AAAASFI Dinner Concert Scholarship
\$1,000 for 1 year - Mason R Palmer - Grandchild of CAPT Robert Palmer, Pleasant View UT - Utah State University



Systems Studies & Simulation, Inc AAAASFI Dinner Concert Scholarship
\$1,000 for 1 year - Whitney N Kimberlin - Daughter of CSM Douglas Kimberlin, Sulphur OK - East Central University



Systems Studies & Simulation, Inc AAAASFI Dinner Concert Scholarship
\$1,000 for 1 year - Eric Raus, Kansas City, MO - Liberty University



Vietnam Helicopter Pilots Association (VHPA) Dinner Concert Scholarship
\$1,000 for 1 year - Michelle A Pollok - Daughter of CW2 Ray Pollok, Granada Hills CA - California State University, Fullerton



Vietnam Helicopter Pilots Association (VHPA) Dinner Concert Scholarship
\$1,000 for 1 year - Katerina J Levinson, Austin, TX - University of Oxford



Vietnam Helicopter Pilots Association (VHPA) Dinner Concert Scholarship
\$1,000 for 1 year - Ashton B Barlowe - Grandchild of CW4 Albert Smith, Kannapolis NC - Appalachian State University



Vietnam Helicopter Pilots Association (VHPA) Dinner Concert Scholarship
\$1,000 for 1 year - Tyler K Williams - Grandchild of Mr. Tyler Williams, Dublin OH - Miami University



Vietnam Helicopter Pilots Association (VHPA) Dinner Concert Scholarship
\$1,000 for 1 year - Blake M Fox - Grandchild of Capt Michael Guttau, Treynor IA - Iowa State University



Contribute to #10516.

Please contribute to the AAAASFI through the Combined Federal Campaign (CFC) program.

The AAAA Scholarship Foundation, Inc. provides a variety of annual scholarships to hundreds of students seeking higher education: Soldiers, NCOs, warrant & commissioned officers & to their family members. Your tax-deductible donation helps make a difference to those looking to further their educational opportunities. See your unit CFC representative for details on participating in the 2024 CFC Program.

The AAAA Scholarship Foundation, Inc., 593 Main Street, Monroe, CT 06468-2806
Email: aaaa@quad-a.org (203) 268-2450



**AAAA is Family.
We take care of our own.**

Give to the AAAA
Scholarship Foundation.



LEARN MORE AT
WWW.QUAD-A.ORG/SCHOLARSHIP

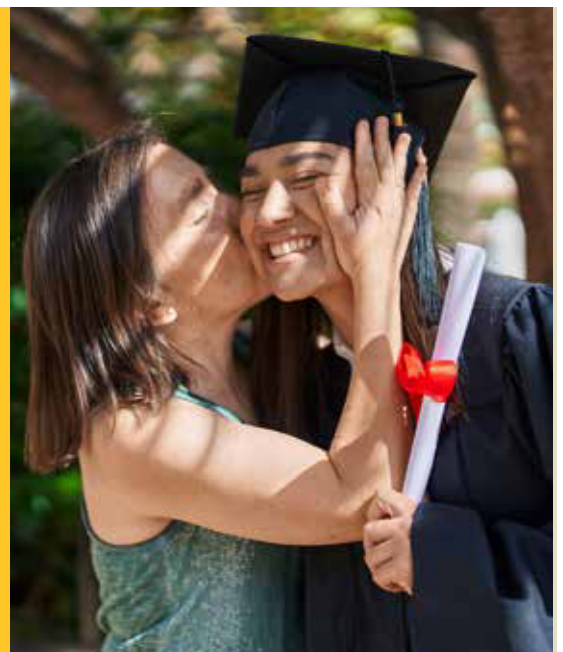

Vietnam Helicopter Pilots Association Special Feature



A Company, 159th Pachyderms

By Andrew Belmont, VHPA Life Member

Editor's Note: This is the next in a series of articles throughout the year taken from the pages of The VHPA AVIATOR, the newsletter of the Vietnam Helicopter Pilots Association. Preserving the Legacy! Enjoy.

CW4(Ret.) Joe Pisano, RVN 1970-1971



WO1 Tom Andrews



SP4 Salinas



SP4 Sweeney

Throughout U.S.A. military history there have been numerous occasions where Army units have aided Marine Corps units in their combat operations. No shame or blame on the Corps as the Army has more manpower and heavier weapons to support sustained operations.

There was a unique situation during the month of March 1969 when a single Army aviation company of 16 CH-47 helicopters with five crew members each, influenced combat operations for the 3rd Marine Corps Division, I



LTG Richard Stilwell

ALL PHOTOS: ANDREW BELMONT PERSONAL PHOTO

Corps Military Operational Area aka Demilitarized Zone. The A Company - "Pachyderms" - of the 159th Aviation Battalion, 101st Aviation Group, 101st Airmobile Division suspended its ongoing operations adjacent to the 3rd Marines and moved slightly north to Marine Corps Vandegrift Combat Base.

Beginning on the first of March '69 the USMC launched Operation Purple Martin to force the North Vietnamese Army (PAVN) 246th Regiment out of South Viet Nam and to secure the southern half of the DMZ. A Co. arrived on the 1st of March and stayed at Vandegrift till 1 April. With just two weeks of A Co. support Marine commanders from company level to division level recognized that the Pachyderms were turning the tide of Marine combat operations with timely, gallant, unparalleled support.

To show USMC Command's appreciation a 'sincere pat on the back to A Co. crews' was demonstrated with a presentation of 'Impact Valor Awards' on 19 March '69 at the Vandegrift helipad.

LTG Richard Stilwell, USA, XXIV Corps Commander, Maj Gen R. Davis 3rd Marine Commanding and BGen F. Garretson Assistant Division Commander presented six Distinguished Flying Cross medals and twenty-two Air Medal w/Valor device. Unfortunately, a number of the Vandegrift awards were not recorded in individual DD201 files with the supporting General Orders (G.O.), the paperwork necessary for Veteran benefits as well as the personal recognition of those challenging days of combat with a determined foe of PAVN regulars.

Concerning the mid-March 'Impact' awards of the six DFCs presented only four had proper G.O. paperwork and only four of the twenty-two Air Medal w/V were recorded with G.O. and none of the enlisted crewmen received proper G.O. paperwork.

On the first of April, A Co. resumed its regular operations with the 101st out of its Phu Bai helipad - "The Beach." In May of '69 the U.S. Army recognized A Co.'s valor during the second two weeks of its Marine Corps assignment of March. LTG Stilwell and MG Melvin Zais, 101st Commanding, presented ten Distinguished Flying Cross medals and twelve Air Medal w/Valor device.

Fortunately, the Army's May awards were recorded with G.O. paperwork but there were two issues of concern with these awards. During April of '69 several crewmen rotated home and were not recognized in the May ceremony and a DFC recipient at Vandegrift had been shot down and KIA along with his entire crew.

As the Internet has become an "Information Highway" I set out on a quest to find out if CW2 Harold Eckert (KIA) was properly recognized for his two DFCs and was his family notified of his heroism. If you have ever tried to correct your military records of years gone by, you may appreciate that as a non-relative of Harold, the task of securing official information about a comrade was a challenge. In this case where to even start? Army, Marines, 101st, or Pentagon?

I was able to track down a source who took interest in my request, at the U.S. Army Human Resource Command, Fort Knox, KY. So back and forth with email the government man confirmed that Harold Eckert family did have information about one DFC, the Army May award. CW2 Harold Eckert family was somewhat aware their loved one was heroic and I hope it eased the reality of his KIA. But there was still the matter of the second DFC that Harold had earned.

Aware that there were still so many other A Co. crewmen without General Orders officially documenting their heroism, I searched for more information. I discovered that military general orders are stored at The National Archives at College Park, MD. By further on-line search of The National Archives, I was able to find ARC Identifier 2,579,373/MLR Number A1 250/Boxes 1 - 54 Series record group 472.

This series of the Archives file system are unique to the 101st RVN 1969. These records include daily Army military matters such as: promotions, reassignment, transfer in and out of country, etc. and recording awards and decorations. All other Army units can be tracked down with similar Identifiers. None of these records are available on-line but can be viewed and copied in person at College Park, MD.

I volunteered my brother Paul (Col, USAF (Ret.)) and his wife Peggy who lived in Northern VA to visit the Archives in MD. One must register with the Archives, pay a small fee, watch

a video on proper handling of official documents and when all the i's are dotted and the t's crossed one is good to go for repeated visits to the Archives. I suggested names of A Company pilots and listed a few G.O. numbers that I gathered from fellow Pachyderms that remain in frequent contact via email.

Paul and Peggy did diligent research of many boxes with thousands of records in each box to determine that the name markers and specific order numbers that I suggested were found with recorded G.O. paperwork, but other names I was interested in, e.g., Harold Eckert with unknown G.O. number, could not be found. Paul noted that the file boxes had numerous inserts noting that G.O. xxx1 could not be found or xxx8 thru xxx15 not found.

Four years ago, I attended a mini-reunion of former A Co. enlisted mechanics and Chinook flight engineers and connected with three of the FEs that I flew with in March '69. We confirmed our connections of those days and were enlightened by each other's perspective. Guy in front seat vs guy in the rear watching, directing internal and external mission loads, monitoring hydraulic systems and an eye on two other crew.

Each FE reported that they did not receive any G.O. paperwork for the Air Medal w/Valor. Going back to the Internet and on-line searching of The Archives did not yield any desired results. I hired a professional archive researcher and as soon as The Archives resumed operation after their Covid shutdown, he took up my search. \$955 later the pro researcher reported "Noted G.O.s Found But Numerous Series Of Missing Files That Could Be Relevant."

The pro did search several other data files but no other Valor awards for A Co. 159th ASHB were found. Bottom line the G.O.s that were recorded in one's DD201 file were found in the Archives, G.O.s missing from 201s were missing from the Archive.

Pachyderms! The crewmen of A Company, 159th Aviation Support Helicopter Battalion can stand proud for the extraordinary combat service to the Marines, the Army and U.S.A. The Valor awards were presented and our only record are some faded photographs. Aged like so many of us.



Historical Perspective ▶ 70th Anniversary of Army Aviation Magazine

Editor's Note: Throughout 2023 we will be celebrating the creation of Army Aviation Magazine in March 1953 by Founders, Art and Dotty Kesten, with articles about the 70-year history.

From page 21, Army Aviation Magazine, Vol. 5, No. 10, Westport, Connecticut, October 1957.

Coagulant

Bob Williams

When the AAAA's Executive Vice President, Col. Robert R. Williams, is on the scene, the word is *gel*.

A natural leader, Bob has the capacity to get things done, obtaining the maximum performance from each command he has been given.

The first aviator in the active forces to earn the coveted Master Army Aviator badge, Col. Williams has run the full gamut of AA assignments, parlaying intense drive and keen interest in his work into fifteen fruitful years in Army aviation.

Not averse to putting his head on the block, whether it be for his men or an ideal in which he believes, he is known as a person who is accustomed to tepid to hot water.

As one of his contemporaries phrased it, "Being so intense about Army aviation, there's no status quo with Bob. His sincerity cools the hottest water."

Soloing in Baton Rouge in '35, the USMA graduate served in the '42 Department of Air Training at Fort Sill. During the same year, he received an Army Air Corps Instrument Rating, becoming the first ground force pilot to earn this certificate.

Serious when the occasion demands, he has a lighter side that has left a long trail of victims, all of whom have been delighted to take the brunt of his good-natured hoaxes, practical jokes, or "awards."

Brightening every gathering at which he is asked to say a "few words," his friendly manner is enhanced by his keen wit.

"Bob's the only person I

know who can say the right thing at the right time—or the wrong thing, and still come up a winner," a friend confides. "You either laugh with him or you're amused by his efforts to extricate himself."

While serving as the first chief of the Army Aviation Branch of G-3, he staffed action papers at a time when AA underwent rapid expansion in both equipment and personnel. Being in the first identifiable AA agency on the General Staff he presided in what can now loosely be described as the diameter of the target's "five" circle.

Now the President of the U.S. Army Board at Fort Rucker he is concerned with the operational evaluation of all types of new AA equipment.

Although he does not claim to be a perfectionist, he surrounds himself with the best personnel available and has been known to handpick his cohorts in all ranks and grades. This round peg in the round hole approach bears fruit—a loyal, conscientious command.

A constant traveller, he may be in Culver City one day and Hagerstown the next. His "home front" counterpart, Jean, parks his suitcase in the front foyer, keeps a close check on the clean shirts to insure smooth departures, and holds down the fort with sons Blair and Keith and daughter Kathleen.

Knowing that in his office he is prone to scat on a mere phone call, he invariably employs Army aircraft, utilizing his special instrument certificate when



Master AA

needed. You'll find an A.F. Green Card in his wallet, too, an instrument card he has held continuously since '50.

As an steady traveler, there are very few military aircraft cockpits that are unfamiliar to him. He's been fully qualified in all Army aircraft and a host of AF-Navy craft to boot (C-47, B-25, F4U, F6F, T-33, among others.)

A strong exponent of the AAAA, the Colonel feels that the Ass'n can do much to weld esprit and a unity of purpose.

"If, on occasion, we happen to have an exceptionally good time while we're doing this, so much the better," he adds.

(The second in a series of informal profiles on the executive officers of the AAAA.)

Thank You to Our Scholarship Fund Donors



AAAA recognizes the generosity of the following individuals, chapters and organizations that have donated to the Scholarship Foundation, Inc. from July 2022 through July 2023. The list includes donations received for all scholarships, as well as the General Fund which provides funding to enable the chapter, corporate, heritage and individual matching fund programs as well as national grants. Every penny donated to the Scholarship Foundation goes directly towards scholarships as a result of the Army Aviation Association of America subsidizing all administrative costs (minus investment brokerage fees).

AAAA Arizona Chapter
 AAAA Aviation Center Chapter
 AAAA Badger Chapter
 AAAA Big Sky Chapter
 AAAA Bluegrass Chapter
 AAAA Connecticut Chapter
 AAAA Delaware Valley Chapter
 AAAA Gold Standard Chapter
 AAAA Great Lakes Chapter
 AAAA Griffin Chapter
 AAAA Idaho Snake River Chapter
 AAAA Lindbergh Chapter
 AAAA Minuteman Chapter
 AAAA Mount Rainier Chapter
 AAAA North Star Chapter
 AAAA North Texas Chapter
 AAAA Old Tucson Chapter
 AAAA Oregon Trail Chapter
 AAAA Southern California Chapter
 AAAA Tarheel Chapter
 AAAA Tennessee Valley Chapter
 AAAA Washington-Potomac Chapter
 Arthur Agnew
 AIRBUS
 Aircrafters, LLC
 AIRTec
 All In Federal Credit Union
 Amazon Smile
 Amentum
 Apache Team Project Office S3
 Janis E. Arena
 Laura & John Arena
 Cribbins Speakers Gift
 Army Otter-Caribou Association, Inc.
 Daphne & Mike Arthur-IHO Maxwell Guida
 ASE Speaker Gift
 Gerald Babor
 Deborah & Robert Barrie
 Charles D. Bayless
 Nolan G. Beck
 Bell
 Helen & Joseph Bergantz
 Michael Betot
 Timothy J. Bevis
 Robert P. Birmingham
 Celeste & Paul Bogosian
 John S. Bolton-IHO CSM Isaac B. Sheffield
 Keirn Brown
 Mary & John Burke
 Stephen T. Burns
 Cynthia S. Campbell-IHO CW4 Richard Campbell
 Dee Campobasso
 Chip Carter
 Combined Federal Campaign
 Clayton Associates
 Charles T. Climer

AAAA Colonial Virginia Chapter
 David Cooper
 Danny Charles Cox
 Rick Crogan
 William T. Crosby
 Patrick F. Curran-IHO Fallen Aviation Brethren
 Walter L. Davis
 Gail Davis-IHO Don & Ruth Luce
 Robert L. Davis
 Geoffrey R. Downer
 Raymond Stephen Doyle
 Michael Doyle
 Gail & Jan Drabczuk
 Craig Dupuy
 Dustoff Association
 Timothy J. Edens
 En-net Services
 Marshall Eubanks
 John Conrad Fabie
 Gregory David Fix
 Susie & Keith Flail
 Michael C. Flowers
 Vanessa & Jeffrey Fowler-IHO Maxwell Guida
 Johnathan B. Frasier
 James G. Freeman
 Jane Froehlich-IHO Emma "Cass" Garfola
 Jenny & Paul Gale
 Galvion
 Charlotte & Ray Faust-IHO Emma C. Garfola
 GE Aerospace
 General Atomics Aeronautical Systems, Inc.
 Robert E. Godwin
 Steven C. Goetz
 Thomas O. Graft-IHO Joel R. Graft
 Mark W. Grapin
 Andy Griffith
 Constance E Hansen-IHO CW3 Stephen Hansen
 Joanne E. Hansrote
 William R. Harris, Jr.
 Thomas M. Harrison
 Gregory B. Hartvigsen
 Kellie Hauenstein-IHO Maxwell Harris Guida
 Ralph C. Hedden
 Robert Helmke
 Olivia and Gerald Hipp
 William F. Hipple
 Scott W. Hollingsworth
 LuAnn Holmes-IHO Ernest & Clara Holmes
 Edmund W. Hubard
 LaVerne Sue Humpert-IHO Gabriel Spicer

James Earl Hyers
 Immersive Wisdom
 Interagency Readiness Solutions LLC
 JACS Aircraft Certification Specialists
 Jack A. James-IHO T/SGT Karl P. Danckwerth Sr.
 Larry Jess
 Devon John
 Thomas M. Johnson
 Johnson Outdoors
 Kathryn's High Tee-IHO 1LT Kathryn M. Bailey
 Brad J. Killen
 Thomas J. Konitzer
 Jonathan P. Koziol
 Carl J. Kreisel
 Carol & Ronald Kurowsky
 F. Harold Kushner
 Steven J. Labows
 Christopher W. Logsdon
 Timothy A. Lunger
 M1 Support Services
 Elisabeth & Daniel T. Madish
 Gregory Maguire
 Kevin W. Mangum
 Truly & Tommy Marks
 Stephen T. Mauro
 Thomas McGurn
 William H. Morris
 James Mulhall
 Betsy & Steve Mundt-IHO Jim Head
 Donald T. Munsch, Munsch & Co. Aeromechanics
 Ann & Bruce Murray-IHO Emma "Cass" Garola
 MyHy Liquid Hydration Mix
 James R. Myles
 7/17th Air Cav Association
 Northrup Grumman Systems Corp
 John E. Novalis
 David Michael O'Briend
 Mary Lynn Osborn-IHO Joel R. Graft
 Ostovich Enterprises, Inc.
 Amber & Brent Pafford
 Laurie & Ralph Pallotta
 Roman Papierz
 Derek J. Paquette
 Marilee Patrick & Sandra Becker
 Patriot Taxiway Industries
 Kimberley Smith-IHO COL Terry M Peck
 Peduzzi Associates, LTD
 Michael E. Perry
 Barbara & Daniel Petrosky
 Jeremy G. Pfeifer
 Phantom Products, Inc.
 Piasecki Foundation
 Gaines T. Pickett-IHO Paul Hendrickson

Nicole Powell-Dunford
 Radial Solutions Inc.
 Recoil Aerospace, Inc.
 Reininger Aviation Services LLC
 William R. Rhodes
 Marilyn & Jaros Rickmeyer
 John M. Riggs
 Fredric Robins-IHO Veterans
 Galen Rosher-IHO CW3 James White
 Galen Rosher-IHO LTC Dennis McMahan
 Kenneth T. Royar
 Latny & Jonathan Salt
 Edward G. Sauvageau
 Michael Schrupf-IHO MG R. Molinnelli & LTC G. O'Grady
 Science & Engineering Services, Inc.
 Kathryn Seidler & Ken Walker
 Ray K. Sellers
 Nancy Shaffer-End-IHO 1LT Kathryn M. Bailey
 Shashy Family Charitable Fund
 Mary & William J. Shelt-IHO Carl McNair
 Sikorsky, a Lockheed Martin Co.
 Susan and EJ Sinclair
 Alan Smith
 Bradford L. Smith
 S3-System Studies & Simulation, Inc.
 Kenneth Smith
 Monica T. Southerland
 Jon Spaulding-IHO Emma "Cass" Garfola
 James M. Sprayberry
 Strata-G Solutions LLC
 Kathryn Taylor
 James D. Thurman
 Maria Del Carmen Tuohy
 John M. Vannoy
 Matthew D. Vennie
 VFW Post 3054
 VHPA-IHO Fallen Troopers of the 227th Helicopter Battalion
 Vietnam Helicopter Pilots Association
 Henry H. Waller
 Wayne Walusiak
 Carol B. Webster-IHO Cub Club
 Karen White-IHO CW5 Frank E. White
 Wreaths Across America
 Jessica & Chuck Wright
 Michelle F. Yarborough
 Yoste Strategic Partners, LLC
 The Zieff Family Fund Inc.-IHO Bill Harris

IHO – In Honor Of

For more information about the Foundation or to make a contribution, go online to www.quad-a.org; contributions can also be mailed to AAAA Scholarship Foundation, Inc., 593 Main Street, Monroe, CT 06468-2806.



AAAA Chapter Affairs

By LTC (Ret.) Jan Drabczuk

I greatly appreciate the support from COL G. Patrick Schuck, Griffin Chapter President for sharing this information to our membership.

The Griffin Chapter

The Griffin Chapter is affiliated with the 12th Combat Aviation Brigade, US Army Europe-Africa's only permanently assigned CAB.

With an area of responsibility encompassing a quarter of the globe, the brigade is consistently engaged in exercises and operations supporting US allies and partners. Founded in Jan 1976, the Griffin Chapter, with more 100 members, supports these US Army Aviation Soldiers, Families, and Retirees across six installations in Germany.

Notable Events and Initiatives

2023 has been a phenomenal year for the Griffin Chapter and the affiliated 12th Combat Aviation Brigade. During operations spanning the European theater in response to Russian aggression in Ukraine, several Griffin Chapter members have made tremendous contributions to the Aviation enterprise and were recognized by AAAA National with the Logistics Technician of the Year Award (CW3 Ross Bogard), the James H. McClellan Aviation Safety Award (CW4 Miguel Miranda), and the Gary G. Wetzel Army Aviation Soldier of the Year Award (SGT Megan Weir). Additionally, the Griffin Chapter and 12 CAB were selected as the Outstanding Aviation Unit of the Year.

Alongside regular meetings and recruiting events, the Griffin Chapter hosts two marquee events each year.

The "CPT Jay Brainard and Chief Warrant Officer 5 John Pratt Memorial Golf Tournament" is held annually in late spring or early summer at Golfclub Lichtenau-Weickershof. The event is heavily attended by Chapter Members, families, and guests from within the brigade and local community, with attendance often approaching 100 players. The Griffin Chapter and local enterprises sponsor the event and provide awards to recognize notable achievements on and off the course. The event serves as both a fundraiser and a community and Chapter engagement event, connecting members with the local community and the tradition of professionalism and selfless service modeled by the event's namesake aviators, who gave their lives while serving with 12 CAB during Operation Enduring Freedom.

The Griffin Chapter AAAA Ball is typically held in the spring each year. 2023's event occurred in April and was hosted in Würzburg, Germany, with a keynote speech by Lieutenant General John Kolasheski, commander of US Army V Corps. The generous sponsorship of AAAA, as well as Griffin Chapter fundraising drives, made the memorable event accessible to almost 400 Chapter Members, Griffin Soldiers, friends, and guests.

The Griffin Chapter AAAA Scholarship initiative awards



US ARMY PHOTO

\$2,000 annually to members and their families to assist with higher education. With 12 CAB's garrisons being located overseas, the scholarship awards provide vital assistance to students outside the United States.

Membership Trends and AAAA Engagement

The Griffin Chapter's success over the past five years is a direct reflection of the dedication and commitment by Chapter leaders and the deliberate support of the AAAA national office. Memberships in the Chapter decreased in response to the 2014 Aviation Restructuring Initiative, which halved 12 CAB's rosters. However, membership has steadily increased in response to the remarkable efforts of local and national offices in organizing and sponsoring events and opportunities that engage with and improve the lives of our Soldiers, communities, and families. In 2023, 12 CAB was recognized with the "Top Gun" award for adding the highest number of new members out of all AAAA Chapters.

The Griffin Chapter will continue to cultivate an environment of support for our Soldiers, aviators, families, and communities. The Chapter invites your inquiries, support, and attendance in their initiatives to shape the future of Army Aviation.

Feel free to contact me if you need help for your Chapter, Executive Board support, would like your Chapter featured in the AAAA magazine or to obtain clarification of National procedures.

LTC (Ret.) Jan S. Drabczuk
 AAAA VP for Chapter Affairs
jan.drabczuk@quad-a.org

AAAA Chapter News

Air Assault Chapter Meeting



CHAPTER PHOTO BY MAI (RET.) SCOTT HOLLINGSWORTH

More than 120 attended the chapter quarterly meeting on July 12, 2023 at Fort Campbell, KY with AAAA National President, MG (Ret.) Walt Davis, as the guest speaker. Chapter President, COL (Ret.) Hawk Ruth, inducted the commanding general of the 101st, MG JP McGee, as a Knight of the Honorable Order of St. Michael as well as 6 other Order of St. Michael inductees (see page 130). Pictured are (l to r): Ruth (gray blazer), COL Roger Waleski, Commander, 160th SOAR (A); McGee; behind McGee, Davis; COL Clint Cody, Commander, 101st CAB; behind him, BG (Ret.) Howard Yellen, former President of AAAA; CSM Lativia Williams-Green, 101st CAB; and behind her, MG (Ret.) Todd Royar former division deputy commanding general.

Arizona Chapter Scholarship Fundraising Golf Scramble



CHAPTER COURTESY PHOTO

On May 6, the chapter hosted its annual Dimmery-Koch Memorial Scholarship Golf Classic at the scenic Apache Wells golf course in Mesa, AZ. 96 golfers participated in the event which has raised funds to provide over \$110,000 in scholarships since 2006. Pictured are the winning team from Northstar Aerospace: (l to r) Aaron Hayes, Brian Cointreau,

Mark O'Cheltree, and Jonathan Horne. The event was sponsored by the Arizona Vertical Flight Society, Arizona Chapter of the Association of the United States Army, GE Aerospace, Inter-Costal Electronics, NorthStar Aerospace, Honeywell, MD Helicopters, and Solano Law Firm.

Griffin Chapter



CHAPTER PHOTO BY CPT GABRIELLE HALDEBRAND

The Griffin Chapter hosted a formal military ball on April 6th at the Congress Centrum Wurzburg, Germany with the commanding general of V corps, LTG John S. Kolasheski as guest speaker. The evening celebrated V Corps and the 12th Combat Aviation Brigade's achievements over the past year. 12CAB is the 2022 AAAA Outstanding Aviation Unit of the Year and is also home unit for three other AAAA annual award winners for 2022 – CW3 Phillip R. Bogard, Logistics Support Technician of the Year; SGT Megan A. Weir, Gary G. Wetzel Aviation Soldier of the Year; and CW3 Miguel T. Miranda, the James H. McClellan Aviation Safety Award.

Lindberg Chapter

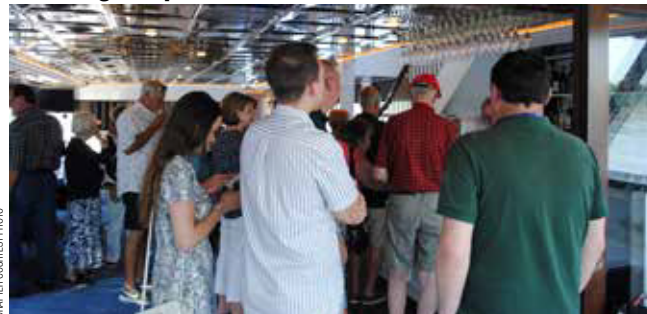

CHAPTER COURTESY PHOTO

The Lindbergh Chapter held their second quarter event on June 28, 2023 aboard the Miss Augusta River Boat for a sunset cruise. This was a cruise on the Missouri River and there was a buffet meal along with bar service. The 38 attendees had a great time.



AAAA NATIONAL AWARDS ARE OPEN!

Awards To Be Presented at the 2024 Annual Army Aviation Mission Solutions Summit:

- Joseph P. Cribbins Department of the Army Civilian of the Year
- James H. McClellan Aviation Safety
- Henry Q. Dunn Crew Chief of the Year
- Army Aviation Soldier of the Year
- Rodney J.T. Yano NCO of the Year
- Michael J. Novosel Army Aviator of the Year
- Robert M. Leich Award
- Army Reserve Aviation Unit of the Year
- John J. Stanko Army National Guard Aviation Unit of the Year
- Active Army Aviation Unit of the Year
- Outstanding Army Aviation Unit of the Year

January 1 Suspense quad-a.org/awards

Recognize Our Soldiers and Units! Send in Your Nominations Today.



ORDER OF ST. MICHAEL INDUCTEES

Air Assault Chapter

During a chapter quarterly meeting attended by more than 120 on July 12, 2023 at Fort Campbell, KY with AAAA National President MG (Ret.) Walt Davis as the guest speaker, chapter president, COL (Ret.) Hawk Ruth inducted the following 6 chapter members into the Bronze Honorable Order of St. Michael: **CW4 Rafael J. Solis, CW4 Sean A. Spears, CW3 Matthew B. Curran, CW3 Ahmed J. Edwards, CW3 Jesse S. Olmstead, and MSG Nicholas D'Andria.** They were each recognized for their efforts in support of the Soldiers and families of the 6-101 Avn. battalion dealing with the March 29, 2023 crash of two Black Hawks that claimed the lives of nine MEDEVAC Screaming Eagles.

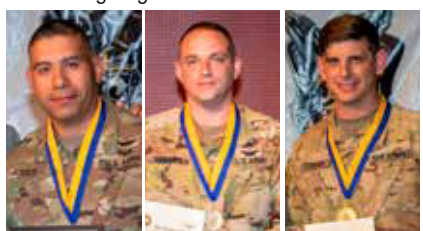

CW4 Solis CW4 Spears CW3 Curran



CW3 Edwards CW3 Olmstead MSG D'Andria

Aviation Center Chapter



CW5 Steven D. Farabaugh was inducted into the Silver Honorable Order of St. Michael by James "Bo" Thurman, Training Division Chief during a June 9 ceremony held at the Directorate of Training & Doctrine (DOTD), U.S. Army Aviation Center of Excellence, Fort Novosel, AL. Farabaugh was recognized for his career-long dedicated support to Army Aviation, culminating as the DOTD Flight Training Branch Chief.

Colonial Virginia Chapter



CW5 John A. Erickson is inducted into the Silver Honorable Order of St. Michael by MG Thomas R. Drew, commanding general of Human Resources Command, during a June 30, 2023 ceremony at Felker Army Airfield, Joint Base Langley-Eustis, VA. Erickson was recognized for his many contributions to Army Aviation over 29 years of service, especially most recently as a fixed wing instructor pilot with the Aviation Technology Office at JBLE.

Tennessee Valley Chapter

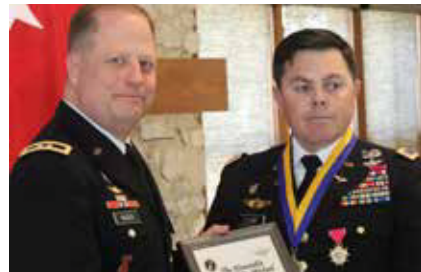

CW5 Kevin Clark is inducted into the Silver Honorable Order of St. Michael by then Director of the Future Vertical Lift Cross-Functional Team, MG Walter T. Rugen, during a June 2, 2023 ceremony at Redstone Arsenal, AL. Clark was recognized for his over 23-years of service to Army Aviation accumulating 5,000+ flight hours as an AH-64A/D/E Standardization Instructor Pilot and culminating in developing requirements for the future fleet as the Future Vertical Lift Lethality Subject Matter Expert/Lead.



COL Altheria M. Niles, Jr. and Mrs. Amy Niles are inducted into the Silver Honorable Order of St. Michael and the Honorable Order of Our Lady of Loreto, respectively,

by chapter senior VP and Apache Project Manager, COL John (Jay) Maher, during a June 15, 2023 ceremony at Redstone Arsenal, AL. The Nileses were recognized for their more than 25 years of significant contributions and support to Army Aviation, culminating with his service as the Project Manager Cargo & Multinational Aviation Special Projects.



CW3 (Ret.) James H. (Hal) Ridley is inducted into the Silver Honorable Order of St. Michael by COL Calvin Lane, Project Manager Utility Helicopters, during a June 6, 2023 ceremony at Redstone Arsenal, AL. Ridley was recognized for his more than 46 years of support to Army Aviation on both active duty and as a Department of the Army Civilian, culminating with his accomplishments as deputy product manager of the UH-72 Lakota Product Office.



LTC John Seitz is inducted into the Silver Honorable Order of St. Michael by CSM (Ret.) Randy Wise, Future Vertical Lift Cross-Functional Team at a June 9, 2023 ceremony at Redstone Arsenal, AL. Seitz was recognized for his accomplishments as the product manager for Aviation Architecture and Environment Exploitation where he fielded the Degraded Visual Environment System, developed and fielded the Integrated Cueing Environment, and developed the Aviation Mission Common Server.



Want to change your AAAA Chapter Affiliation? No Problem!

Call 203-268-2450

In Memoriam



U.S. ARMY PHOTO

Major General Anthony Wayne Potts, U.S. Army

It is with great sadness that AAAA announces the passing of MG Anthony W. "Tony" Potts on July 25, 2023. He was 59. Potts was the only casualty when the Piper single-engine aircraft he was piloting crashed in the early evening hours into a wooded area in Havre de Grace, Maryland. The accident is under investigation by the FAA. An AH-64-qualified Senior Army Aviator and veteran of Operation

Desert Shield/Desert Storm and numerous deployments to the Balkans, Operation Enduring Freedom and Operation Iraqi Freedom, he most recently served as Program Executive Officer for Command, Control and Communications (Tactical) from June 22, 2022 to June 2023. Prior to that he served as the Program Executive Officer Soldier of the United States Army, as the Deputy Commanding General of the United States Army Research, Development, and Engineering Command and Senior Commander of the Natick Soldier Systems Center. A funeral service was held August 29 at Aldersgate United Methodist Church, Alexandria, VA and interment immediately following with full military honors at Arlington National Cemetery.

May he rest in peace.

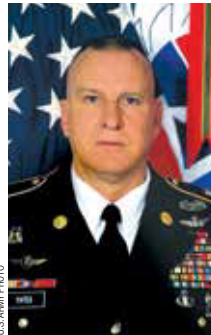

U.S. ARMY PHOTO

Command Sergeant Major Ricky Paul Yates, U.S. Army Retired

AAAA also announces with great sadness the passing of CSM Ricky P. Yates on July 29, 2023, in Fairview, AL at age 63. He enlisted on July 1, 1977 and served honorably until his retirement on July 31, 2012. In his final assignment prior to retirement, he served as the Command Sergeant Major for Army Aviation and Missile Command at Redstone Arsenal, AL for 5 years. He served for over two decades in the 82nd Airborne Division and is an 82nd Airborne Division Hall of Fame inductee. He served in Operation Desert Storm/Desert Shield, Operation Iraqi Freedom and Operation Enduring Freedom. He was inducted into the Gold Honorable Order of St. Michael in 2014. Following his retirement, he joined DynCorp/Amentum as the director of the Aviation Field Maintenance-West program. A funeral service was held on Aug. 4 at Fairview Methodist Church, Cullman, AL and interment with full military honors immediately followed at the church cemetery.

May he rest in peace.



CHAPTER PHOTO BY WILLIAM SIEGERS

MAJ (Ret.) Timothy J. Vinson is inducted into the Silver Honorable Order of St. Michael by COL Calvin Lane, Project Manager Utility Helicopters, during a June 6, 2023 ceremony at Redstone Arsenal, AL. Vinson was recognized for his dedicated service to Army Aviation over more than 38 years on both active duty and as a Department of the Army Civilian culminating with his accomplishments while serving as the UH-72 Lakota Product Manager.



CHAPTER PHOTO BY ELIZABETH GRANAM

CPT Ronald Ramsey is inducted into the Bronze Honorable Order of St. Michael

by COL Al Niles, Project Manager Cargo & Multinational Aviation Special Projects during a June 5, 2023 ceremony at the Cargo PMO at Redstone Arsenal, AL. Ramsey was recognized for his contributions to Army Aviation while serving as the assistant product manager of CH-47F(Block 1) program.



CHAPTER PHOTO BY MAJ IMBRAHIM CIRIOCCO

MAJ Trevor J. Roberts is inducted into the Bronze Honorable Order of St. Michael by UH-60V Product Manager, LTC Mark Swanson, during a June 7, 2023 ceremony at Redstone Arsenal, AL. Roberts was recognized for his significant contributions to Army Aviation over the past 18 years and while serving as the assistant product manager for the UH-60V on the occasion of his change of duty to the Technology Applications Program Office (TAPO) at Joint Base Langley-Eustis, VA.

Washington Potomac Chapter



CHAPTER COURTESY PHOTO

LTC Benjamin T. Channels is inducted into the Silver Honorable Order of St. Michael by COL Brendan Cullinan (far left), commander of The U.S. Army Aviation Brigade, and Mr. Dan Curry, chapter vice president for awards, during a June 23, 2023 ceremony at Davison Army Airfield, Ft. Belvoir, VA. Channels was recognized for his significant and long-lasting impact on Soldiers, their families, and the Army aviation community at large during multiple assignments including with the 25th Infantry Division, 160th Special Operations Aviation Regiment (Airborne), Army Human Resources Command, the Joint Staff, and as commander of the 12th Aviation Battalion. Also pictured is CSM Alex Collins, 12th Avn Bn CSM.



AAAA

NETWORK | RECOGNITION | VOICE | SUPPORT



AAAA Membership Update By CW4 (Ret.) Becki Chambers

The Membership Corner

As the Vice President for AAAA Membership, one of the duties I am assigned during Summit is to be a point of contact for the Sponsored Soldiers.

The Sponsored Soldier program is just one of the many programs that fall under Recognition – one of our four pillars of Network, Recognition, Voice, and Support.

The **Professional Forum Soldier Sponsorship Program** was created to help underwrite the cost of sending one Junior Soldier (LT, WO1, E1-4), from each AAAA Chapter to the AAAA Annual Professional Forum. AAAA provides one room, registration, and tickets to all events for a Soldier and his/her spouse from each *Chapter*. All Chapters need to do is select the Soldier and underwrite the travel cost of getting them to Summit. This program gives the Chapters a way to show their appreciation for the outstanding achievements our maintainers, crew chiefs, ATC professionals and all our Soldiers accomplish year-round.

Another Recognition program is the **Top Gun Recruiter** award. Top gun recruiters are those who recruit the most members, and they are also tracked by Chapter. Here are the end of year 2022 winners that were recognized at the summit.

AAAA "TOP GUN" Individual Membership Recruitment

- MAJ James Raymond, Griffin Chapter enrolled 20 new members



Then-AAAA National President, MG (Ret.) Tim Crosby, visits with seven of the 16 chapter-sponsored Soldiers during the 2023 Army Aviation Mission Solutions Summit at the Opryland Hotel in Nashville, TN.

- CSM William Ritter, Thunderbird Chapter enrolled 17 new members
- SFC Wes Obenauer, Idaho Snake River Chapter enrolled 10 new members
- SGM Kenneth Rich, Ret., Colonial Virginia Chapter enrolled 10 new members
- COL Jim Barker, Ret., Arizona Chapter enrolled 9 new members
- SFC Jeremiah Mowdy, North Texas Chapter enrolled 9 new members

AAAA Top Recruiter by Chapter Category

- **Super Chapter:** SSG Dean Phillip, enrolled 4 new members
- **Master Chapter:** CSM William Ritter, enrolled 17 new members
- **Senior Chapter:** MAJ James Raymond, enrolled 20 new members
- **AAAA Chapter:** CPT Jacob Conner, enrolled 6 new members

Anytime during the year you will be recognized for your recruiting efforts. Recruit one new member and you will receive an AAAA coin. Recruit 5 new members, and you will be sent an Amazon e-gift card for \$5.00.

Chapter Programs to Recognize Outstanding Individuals on a Monthly, Quarterly, and Yearly Basis

Each Chapter has the option to recognize outstanding individuals on a monthly, quarterly, and yearly basis. Each Chapter can select an Aviation Soldier (E4 and below), NCO, or DAC of the Month, who will receive a complimentary, one-year Association membership sponsored by AAAA. Additionally, awards can also be presented for the Soldier, NCO, or DAC of the Quarter (4 per year), along with a Soldier, NCO, or DAC of the Year.

Instructors can also be honored with the Distinguished Instructor of the Month and Distinguished Instructor of the Year awards.

Details about these awards, and applications, can be found on the website at https://www.quad-a.org/Public/Chapters/Chapter_Ops/Recognizing_Outstanding_Aviation_Soldiers.aspx Please do not hesitate to reach out if you have any questions about these awards.

CW4 (Ret.) Becki Chambers
AAAA Vice President for Membership

New AAAA Life Members

Aviation Center Chapter
COL Joshua P. Higgins
CW4 Jason Starr
Flint Hills Chapter
CW2 John Dietrick
Gold Standard Chapter
CW4 Michael A. Yourous, Ret.
Greater Atlanta Chapter
CPT James Fink, Ret.
Iron Mike Chapter
CW3 Ian Kalgren
Lonestar Chapter
CAPT John Egan
North Texas Chapter
CW2 Robert Crain
Oregon Trail Chapter
MAJ Edward Hester
Pikes Peak Chapter
CW4 Carlo Cavalluzzi
Rio Grande Chapter
CW4 Truel A. Turner, Jr.
ShowMe Chapter
BG Charles D. Hausman
Tarheel Chapter
CW2 Peter Sweeney
Tennessee Valley Chapter
2LT Mitchell A. Bedard
Winged Warriors Chapter
Mr. Todd Haralson
Wright Brothers Chapter
Mr. Nathan Griesinger
CW2 Gary Senkar

New AAAA Members

Air Assault Chapter
LTC Zachary Dadisman
Mr. John P. Harpel
CSM Jackie Mills
CW2 Matthew Minjarez
1SG Aaron Ravenscraft
Aviation Center Chapter
CW3 Gerald Bacoats
W01 Mason T. Berryman
2LT Cameron D. Cloutier
CW2 John R. Costine
CW3 David DeAvila
Mr. Dave Dorman
2LT William L. Erwin
2LT Luke R. Grayson
W01 Blaine L. Hall
2LT Margaret Hammel
2LT Emma R. Heper
2LT Hayden J. Hittle
2LT Jason A. Hoyle
W01 Jose Pio G. Luz
W01 Brian T. May
2LT Ryan P. Messmer
2LT Christopher Metler
2LT Austin G. Miller
W01 Jaelon R. Moore
Mrs. Suzannah Palmer
2LT Daniel A. Park
CAPT jim percival
2LT Emily A. Pickrell
1LT Jacob P. Rhyne
W01 Jonathan R. Rivera
2LT Jacob L. Rogers

2LT Felipe T. Sanchez
2LT Jahob A. Seib
W01 Taylor V. Smith
W01 Leah A. Spangler
2LT Daniel P. Spetz
CW4 Jason Starr
2LT Christopher K. Walker
W01 Bruce Wang
2LT Isaac A. Waters
2LT Jacob M. Withers
Battle Born Chapter
PFC Mitchell Ray Knapp
PV2 Cody Wayrynen
Central Florida Chapter
Mr. Patrick Concilio
Mr. Jason Day
Mr. Mark Evans
CDT Alexandra M. Howell
PV2 Akram Hussain
CDT Matthew A. Klepper
Dr. Daniel J. Lacks
Ms. Tiffany Paulk
MAJ John Rasimas
Ms. Anita L. Waters
Colonial Virginia Chapter
W01 Wesley Aaron Barkley
Mr. William Etchison
SSG Kevin M. Johnson
SSG Joshua Layne
Mr. Karun Sapkota
Connecticut Chapter
Mr. William Buckman
Ms. Elizabeth Garmise
Mr. Craig Hummer
Mr. Eric J. Kraemer
Mr. Brian E. Larson
Mr. Len Margiotta
Mr. Bradley Randall
Ms. Patricia Reed
Ms. Patricia Saglimbeni
Mr. Yogesh Soni
Mr. Eric Wasson
Cowboy Chapter
CW3 Michael J. DeForge
Delaware Valley Chapter
PFC Joseph Anthony Scalia
Desert Oasis Chapter
SFC Anthony Jackson
Follow Me Chapter
CPT Marco Zamora
Gold Standard Chapter
CW4 Michael A. Yourous, Ret.
Great Lakes Chapter
PFC Randall James Bazdor
PV2 Coe Francis Emens, IV
Mr. Mark Holtvlwuer
Greater Atlanta Chapter
SPC Paul Babaz
Mr. Matt Gele
LTC Daniel Kane
Griffin Chapter
CPL Megan A. Weir
Grizzly Chapter
CW5 David Clark
Iron Mike Chapter
CW3 Ian Kalgren
Jimmy Doolittle Chapter
SSgt Coraliz Negronnieves
Keystone Chapter
MAJ Shawn Michael

Dougherty
SFC Stephen Farnack
CW3 Robert Reed
Lindbergh Chapter
Mr. Corey March
Mr. Andrew Zaat
Lonestar Chapter
CAPT John Egan
Mr. Robert Streiferd
MacArthur Chapter
CW4 Robert Hansen
Mr. Mike Sackett
Magnolia Chapter
W01 Rad Lionel Chattelle
Mid-Atlantic Chapter
PV2 Carlos N. Bautista-Tobar
Morning Calm Chapter
Mr. Jason Cates
CPT Timothy Lee
LTC Michael Urso
Mount Rainier Chapter
Mr. Bryan Bakker
Mr. Daniel Borrás
Mr. Mickey Jacobson
Mr. Ryan Zydel
Narragansett Bay Chapter
MG Christopher Callahan
Mr. Ted Grove
PV2 Christopher J. Harrington
PVT Ethan J. Hartmann
North Texas Chapter
Mr. Drew Adams
COL Javier Ball
SPC Don Rubin
CW2 Robert Crain
Dr. Bret Draayer
Mr. Paul C. Grubel
PV2 Justin Michael Leija
CSM Kenneth D. Mudd
Mr. Christian M. Oliverio
Mr. Austin Tulloh
Mr. Edward Weisensale
Oregon Trail Chapter
MAJ Edward Hester
Phantom Corps Chapter
Mr. Michael Miller
Pikes Peak Chapter
CW4 Carlo Cavalluzzi
Mr. Robb Fladry
Mrs. Shelley Fladry
SFC Justin Smith
Ragin' Cajun Chapter
CPT Joseph Kramer
SSG Daniel Pierce
Rio Grande Chapter
CW4 Truel A. Turner, Jr.
ShowMe Chapter
BG Charles D. Hausman
Southern California Chapter
Mr. Marc Polanco
PV2 Dinhphi C. Tran
Tarheel Chapter
CW2 Peter Sweeney
Tennessee Valley Chapter
Mr. Erick Arnell
2LT Mitchell A. Bedard
Mr. Daniel Carr
SSG Billy Carroll
Mr. Charles E. Deiter
Mr. Robert Gibson

SrA Geanna Gomillion
Mr. Jason J. Hayes
Mr. Robert Hurtig
Mr. Stephen Janny
Mr. James Kennedy
CW3 Jon King
Mr. Christopher B. Land
Mr. Jeffrey D. Mainwaring
Mr. Mark Marcus
MAJ Wesley Paulsen
Ms. Remenida D. Singleton
Mr. Dave Stewart
Mr. Duncan Tovar
Mr. Jeff Winchester
Utah Chapter
PFC Jacob S. Lee
Washington-Potomac Chapter
Mr. Crispin Burke
Ms. Gabriella Cikaryssi
CW4 Leland Komich
Mr. Brian Luther
Mr. Gaven Meadows
Mr. Donald Nisbett
Mrs. Megan Resh
MAJ Nicholas Spangler
Mrs. Katherine Walton
Winged Warriors Chapter
Mr. Todd Haralson
CPT Jonathan Scott
Wright Brothers Chapter
Mr. Sage Duggal
Mr. Aaron Geogh
Mr. Nathan Griesinger
Mr. Shawn Reischmann
CW2 Gary Senkar
Yellowhammer Chapter
LTC Steven Witherington
Zia Chapter
Mr. Kevin Butler
No Chapter Affiliation
PV2 Carlos Morgan Alexander
Mr. Stephen Bayer
Mr. Jeff Blake
CW4 Roger Blankenship
Ms. Sara Brown
PFC Larry M. Castorena, JR
CW3 Daniel Jinwoo Choi
Mr. Daniel D'Amore
Mr. Mike D'Angelo
Mr. Keith Dufford
Mrs. Sandy Fladry
Ms. Sheryl Forrest
Mr. Paul Gallagher
Mr. Jason Gokey
Ms. Katharine Harris
Mr. Carl Hood
Mr. Bobby Howard
Ms. Jalyn Hyder
Ms. Kate T. Kaishauri
PV2 Christopher J. Kastner
PV2 Jungsu Kim
SFC Harry Ledbetter
Mr. Richard L. Lewis
Ms. Hailey MacIsaac
1SG Steven M. Miller
CW3 Joshua John Moran
CW3 Raymond L. Norman
CW2 John L. Pecic, II
PFC Benjamin S. Penttila
Mr. Terry Rinehold

LTC Walter Ringler
Ms. Barb Rittler
Mr. Vaughan Sallinger
CPT Ron Salmon
CAPT Gary Smith
CW2 Jim Steele
PV2 Hunter M. Stoliker
Mr. Tony L. Vickery
CW2 Christopher Wareing
Mr. Darryl Webb
Mr. Mark E. Willett
Ms. Hilary Winocoor
CW3 Charles W. Wright
COL Dana M. Young, Ret.
Mr. Christer Zatterqvist
Mr. Edson Zerbini

LOST AAAA MEMBERS

Help AAAA locate a lost member on this list and receive a FREE one month extension to your AAAA membership.
CPT Robert S. Boham
Mr. Harold V. Bowie, Jr.
COL Fred E. Brown, Ret.
LTC Jeffery D. Brown
Mr. Rickey J. Brown
MAJ James E. Bruckart
Mr. E. W. Cavanaugh
LTC Richard G. Cercone, Jr.
LTC Tzu-Shan Chang
COL James A. Coar, Ret.
MAJ Harry L. Connors, Jr. Ret.
Mr. Bruno Cussigh
2LT Arthur W. Galloway
Mr. William H. Gillispie
Mr. Michael F. Glass
MAJ Gregory W. Glover
Ms. Mary H. Gorman
COL Gerhard Granz, Ret.
LT Tyler Grubic, PhD
COL Jose L. Hinojosa, Ret.
CW4 Delbert Jackson, Ret.
LTC Randy K. Jackson
CW3 Jeffrey J. Jelonek
MAJ David A. Jobe
Dr. Morey J. Kolber, PhD
LTC Peter D. Kowal
CW3 Vladimir Kultschizky
CW3 Timothy J. Larz
MSG David W. Little, Ret.
CW4 Mark P. Mata, Ret.
LT Chad Milam
SGM Ivonne M. Morrison, Ret.
MAJ Darrel B. Nerove
Mr. Fred A. Newcomb
1LT Andrew J. Norton
SFC Henry R. Rathbone, Ret.
LTC Martin Scheld
Mr. Thomas R. Schiltz
LTC Jerry D. Scott
LTC Jay Q. Smith
MAJ James F. Speelman
LTC Friedrich Stern
W01 Armando B. Torres
MAJ L.D. Walker
Mrs. Rose Weast



AAA

NETWORK | RECOGNITION | VOICE | SUPPORT

AAAA Family Forum By Judy Konitzer

I appreciate COL Clint Cody, 101st CAB Commander, sharing the challenges along with the phenomenal support he and his unit received upon the tragic loss of nine of their” Screaming Eagles.”

“Blessed Are They Who Mourn, For They Shall be Comforted”

– A Medevac Tragedy!

We live in a world of challenging times, yet thankfully our one constant is the strength of our Army Family and how we can always depend on each other.

Corinthians 13:13 reminds us that “Love always protects, trusts, hopes, perseveres. Love never fails.” When a catastrophic helicopter crash on March 29th killed nine medevac Soldiers assigned to the 101st Combat Aviation Brigade (CAB), we came to realize the frailty of our lives, and yet the ability to amass the goodness of not only our Army family but the love and commitment of our local communities who value and have always supported us in good times as well as bad.

When neighbors, who are usually comforted by the sounds of helicopters flying overhead, hear a loud explosion followed by a bright flash of light, their first instinct is to tweet or text this incident to a larger audience. COL Clint Cody said within 10-15 minutes his unit was on defense vs offense because of social media as local press and folks throughout the country were being notified. Quickly cordoning off the area was imperative, and he thankfully received help from 150 emergency personnel from the Division and local responders. There is normally time to recover the fallen and begin notification, but because of media challenges, they received a DoD exception to policy to expedite this.

Notification was complicated because only 4 families lived in the local Fort Campbell area, others and extended families were from several states and overseas. On-site units from these areas provided casualty assistance, but a Soldier from the Battalion was quickly assigned as a liaison to each family and attended funerals with unit honor guards, a fly-over, along with a General or Colonel. Arlington National Cemetery provided their own Old Guard. Cody emphasized how very important it was for the fallen Soldiers’ families to be properly cared for in the days that followed.

Immediately the local Military Affairs Committees along with the Fort Campbell Community reached out and helped with meals and unit support along with many organizations and countless local businesses like AUSA, AAAA, Screaming Eagle Aviation Association, ASYMCA, USO, Brotallion, Blue Skies Foundation, Black Rifle Coffee, Mission BBQ, as well as many of the local Fort Campbell Units. When Cody’s Soldiers gathered daily in their hangars during the first weeks,



their lunches were provided by local restaurants. Something simple like sharing a meal while they grieved and mentally processed their shock together was greatly appreciated. During these times, Cody shared messages of sympathy he received from all over the country. While acknowledging his own grief, he also encouraged his Soldiers and family members to utilize the Behavior Health Specialists, clinical workers, and Military Family Life Counselors as “they were worth their weight in gold” to help begin their healing process.

Before any funerals, a Memorial Service was held in the F&M Bank Arena in Clarksville on April 13th with over 150 family members from as far away as the Philippines in attendance. Thanks to generous donors, they were flown in and housed at local hotels while CAB spouses assembled and delivered welcome bags with refreshments and gift cards donated by local restaurants and businesses to them. 3,000 dignitaries, Soldiers, and friends of Fort Campbell also came to honor the Fallen where prayers, eulogies, and appreciation was shared along with a video showcasing personal remembrances. At an earlier service, families were presented with their service members’ awards and 3 Soldiers were posthumously promoted.

Matthew 5:4 reminds us that “Blessed are they who mourn for they will be comforted.” MG JP McGee promised that the 101st Abn. Div. would “stand behind the families and friends of our fallen Soldiers.” Kentucky Governor Andy Beshear, Tennessee Governor Bill Lee, along with local community leaders and families also vowed to make sure these families are loved and not alone. We join them and extend our heartfelt condolences and prayers to all the Soldiers and Families of the 101st CAB. The memorial service is available at <https://www.youtube.com/watch?v=jJJ40iT42nE>.

Judy Konitzer is the family forum editor for ARMY AVIATION; questions & suggestions can be directed to her at judy@quad-a.org.

AAAA Awards



Order of St. Michael Inductees

Gold

Aviation Center Chapter
LTC DeVerne R. Yost, Ret.

Silver

Air Assault Chapter
CW5 Robert E. Epting II
Aloha Chapter
COL Robert K. Bryant
LTC Sean H. Karrels
Aviation Center Chapter
COL Jason T. Cook
CW5 Steven D. Farabaugh
SGM John A. Nichols
Colonial Virginia Chapter
1SG Paul T. Reidy, Ret.
CSM Manuel S. Reyes
COL G. Patrick Schuck
Frontier Army Chapter
1SG Russell L. Reese, Ret.
High Desert Chapter
CSM Jose Fontanez
Morning Calm Chapter
LTC Joshua T. Christy
Phantom Corps Chapter
CW5 Thomas P. Hamilton
CW5 Bruce A. Haskins, Ret.
Savannah Chapter
COL Eric A. Vanek
Tennessee Valley Chapter
CW5 Kevin P. Clark
COL Troy G. Flowers
COL Timothy D. McDonald
COL Altheria M. Niles
James H. Ridley
MG Walter T. Rugen
COL Seth O. Swartz
Timothy J. Vinson
Washington-Potomac Chapter
COL Dudley R. Capps
CW5 Scott J. Nalley
No Chapter Affiliation
CW5 William J. Apke
COL Stephen E. Brack
CW5 Charles Doiron
COL Eric E. Ladd

Bronze

Air Assault Chapter
MSG Nicholas D'Andria
CW5 Brian R. Erb
CSM Dylan J. Lemasters
CW3 Jesse S. Olmstead
SFC Seth C. Schroeder
CW4 Rafael J. Solis
CW3 Scott H. Swanson
Aloha Chapter
CW2 Shayvonne Mitchell
Arizona Chapter
CW3 Nicholas S. Hatchel
Aviation Center Chapter
CW4 Richard E. Barnett
LTC Travis Betz

CW3 Keith Bonner
CW3 Christian L. Boomgaard
MAJ Matthew R. Clawson
CW3 Jamie L. Collazo
SFC Justin M. Cox
SGM Charles E. Hancock Jr.
CPT William T. Lane
SGM Shane W. McLaughlin
CW4 Robert W. Nickison
CPT Spencer B. Read
SFC John P. Romanello
SFC Gregory H. Schoning
CW2 Brent A. Unglesbee
SFC Clark C. Urban III
CW4 Nicholas M. Vareka
LTC Charles "Ryan" Walker
SFC Amanda L. Wallace
CPT Joseph Walters
SSG David S. Waters
Bavarian Chapter
CW4 Jeffery Bledsoe
SFC Stephen Davis
SFC Kelly Dunn
MAJ Lindsay Heisler
CPT John Heisler
CW5 Nicholas Jacoby
CPT Rebecca Marshall
MAJ Shane McKiddy
CPT Lee Oeschger
CW4 Ryan Otto
CPT Christina Ramos
CPT Jonathan Theroux
CPT Jacob Veness
CSM Trenton Zaragoza
Central Florida Chapter
MAJ John H. Freeman III
SFC Juan Santiago, Ret.
Colonial Virginia Chapter
Joseph Bonish III
CW3 Stephen C. Daniels
SSG Billy J. Jones
Helen Miller
Jill Rich
SFC Michael G. Seaver
MAJ Kenneth A. Wolfe
Corpus Christi Chapter
Donivan F. Babcock
Desert Oasis Chapter
CW3 William Johnson
SFC Nathaniel S. Stehley
CW4 Adam Stratton
Gold Standard Chapter
CW4 (P) Marc Boxberger
CW5 Jason E. Godwin
SSG Roland A. Ortiz
SGM Elvin Pabon
CW5 T. Brent Pryzchoda
MAJ Jason C. Stanley
LTC John A. Torrealba
Griffin Chapter
SFC Evan Chaney
CSM Robert N. Christensen
CW3 Shawn Fyfe
CW3(P) Miguel Miranda
CW3 Heath Morecraft, Ret.
SFC Matthew Patterson
MAJ James Raymond
SFC Kenneth R. Wilson

High Desert Chapter
CW2 Stefan Dossev
CW2 Scott Keefer
CW2 Gregory King
CW4 Scott Kinney
Iron Mike Chapter
MAJ Christopher E. Batchelor
MAJ Douglas Brauch
CPT Chase Chatterton
CW2 Min S. Choi
MAJ Josh J. Durham
LTC Michael Kinsel
MAJ Shawn Kirby
CW5 Michael A. LeNeave
CW4 Teresa L. Muirhead, Ret.
MAJ Michael S. Poling
CW5 Parker Priest
CW4 Kyle C. Straker
CW4 Josiah Watts
Keystone Chapter
SFC Matthew Boerger
CW4 Richard Paden
MAJ Justin Shedron
SSG Michael S. Sweigart, Ret.
Mid-Atlantic Chapter
CW3 Adriel Burgos
Morning Calm Chapter
CW4 Qasim Ahmed
CPT Emily E. Baugus
CW3 Lance A. Clark
CW3 Austin F. Fillion
CPT Timothy C. Luchs
COL Bo Ryung Lee
MAJ Hana Lee
CW3 Johnathan J. Morzenti
CW3 Thomas J. Pettit
CW3 John W. Vadakin
CW3 Joseph R. Wekkin
MAJ Dustin M. Yates
Mount Rainier Chapter
CW3 Jonathan Attwell
MAJ Christopher T. Benjumea
CW3 David Boring
MSG Derek M. Czerniak
MAJ Alec DeGroat
MSG Christopher K. Diaz-Rose
SFC Chase J. Downey
CW3 Keith Eastman
SFC Nicholas S. Gilmore
1SG Arturo C. Gonzalez
CW3 Zackery Huffman
SFC Charles N. Mbae
1SG Edward McStine
CW3 Matthew Muntifering
CW3 Dominic E. Ochoa
MAJ Matthew J. Palange
MAJ Benjamin L. Salvo
1SG Scott S. Scuderi
SFC Scott S. Smith
SFC Cheri A. Stevens
SFC Norman Westerfeld III
North Country Chapter
CW4 Joshua N. Winkler
Northern Lights Chapter
SFC Jason L. Fenton
1SG Brendan Fergus
1SG Curtis Seegars
Phantom Corps Chapter
CPT Tyler S. Bertles
CW2 Eric T. Blanton
MAJ Brian E. Hernandez
MAJ Brian W. Hewko
CW2 Drew D. Lincoln
CW2 David W. Ray Jr.
CW2 Devon P. Scarletto
MAJ Armando E. Valencia
Prairie Soldier Chapter
CW4 Bradley Kuhn
Rio Grande Chapter
SFC Gordon D. Plotts
Southern California Chapter

SSG Edward Collado
Tennessee Valley Chapter
Edna (Kathy) Willerton
Volunteer Chapter
CPT Jayson L. Cooper
Washington-Potomac Chapter
CW4 Ryan LoFranco
CW3 Juan C. Ortiz-Geerman
LTC Nathan S. Patrick
MAJ Randall W. Phillips
LTC Edward D. Tibbs
MAJ David A. Witt
Winged Warriors Chapter
SFC Fabian Diaz
MAJ Levi Dillon
CW4 Michael Gannon
CPT Ryan Hampton
CPT Alix Idrache
CSM Keith A. Jenkins

Knight



Air Assault Chapter
SFC Cody K. Bernard
SFC Dominique J. Bryant
MAJ Joshua Dunleavy
CPT David Gattie
MG Joseph P. McGee
CH (CPT) Ian Roberts
Aviation Center Chapter
SFC Ian M. Burress
COL Jason C. Caldwell
LTC James E. Word
Bavarian Chapter
CPT Kyle Douglas
MSG Leann Miller
Connecticut Chapter
CPT Nicholas J. Hurley
Gold Standard Chapter
CSM Scott A. Floyd
CSM Anthony Gray
1SG Ruby Mayhan
COL John Schwab
Griffin Chapter
BG Cas Schreurs
High Desert Chapter
Luis A. Colon-Nieves
SFC Marty R. Lockett
William A. Perrine
Iron Mike Chapter
MSG Jonathan E. Gryp
MSG Daniel B. Smith
Keystone Chapter
1SG Joseph Cummings
SFC Daniel Mendolia

Mount Rainier Chapter
CH (MAJ) W. Ryan Steenburg
Phantom Corps Chapter
SFC Jamie C. Fox
Tennessee Valley Chapter
MAJ Joshua K. McMillion
Brian A. Wood
Thunder Mountain Chapter
CW4 Brandon J. Sutton
Winged Warriors Chapter
CPT Christian J. Ramsay
CPT Jerry M. Trout
No Chapter Affiliation
LTC Timothy Aamland
COL Edward A. Johnson
CW3 John D. Murphy Jr.
LTC Leon Parham

Our Lady of Loreto



Air Assault Chapter
Lori Cooper
Erin Danick
Hallie Lee
Aviation Center Chapter
Lisa Maine
Colonial Virginia Chapter
Kathy Malcomb
Georgeann Rabb
Gold Standard Chapter
Samantha N. Yates
Griffin Chapter
Suzanne Scherrer
Kelly Zelman
High Desert Chapter
Lauren Dossev
Jamie King
Iron Mike Chapter
Jennifer A. Hirtle
Karen Iampietro
Trista W. McNamara
Keystone Chapter
Lily Palfrey
Gail Sweigart
Morning Calm Chapter
Katharine M. Christy
Lacie Lyons
Brandy D. Madrigal
Rio Grande Chapter
Michelle L. Bean
Emily E. Litteken
Tennessee Valley Chapter
Amanda L. McDonald
Michelle Moodie
Angela R. Swartz
No Chapter Affiliation
Chenin Doiron

AAAA Salutes the Following Departed...

COL John P. Stewart, Ret.
Deceased 5/21/23, life member

LTC Raymond F. Holleran, Ret.
Deceased 7/12/23, charter member 1958,
life member

CW4 Cleveland Valrey, Ret.
Deceased 4/14/23, life member



People On The Move



U.S. ARMY COURTESY PHOTO

Awards

Widner USMA Cadet of the Year

Cadet Timothy Austin Bradley Widner is congratulated on his selection as the 2023 Outstanding U.S. Military Academy Aviation Branch Cadet of the Year by MG (Ret.) Walter Golden (left), AAAA National Senior Vice President, and COL Richard Melnyk, director of the Academic Flight Program, Department of Civil and Mechanical Engineering, West Point, and Black Knights Chapter president, on May 11, 2023.



Flight School Graduates

AAAA provides standard aviator wings to all graduates and sterling silver aviator wings to the distinguished graduates of each flight class ... *another example of AAAA's SUPPORT for the U.S. Army Aviation Soldier and Family.*



AAAA congratulates the following officers graduating from Flight School XXI at the U.S. Army Aviation Center of Excellence, Fort Novosel, AL.

49 Officers June 29, 2023

Class 23-017

Commissioned Officers

- 1LT Proper, Mikael J. -DG
- 2LT Muennich, Kyle L. -HG
- 1LT Parker, Matthew D. -HG
- 1LT Brown, Orian L. *
- 1LT Hull, Robert T. *
- 1LT Kerr, Caleb G. *
- 1LT Larsen, Michael R.
- 2LT Popielski, Michael P.
- 2LT Richards, Quinn R. *
- 1LT Rivers, Christopher A. *
- 1LT Roarick, Riley T. *
- 1LT Rocha, Nicole D. *
- 2LT Schute, Jennifer L.
- 2LT Scott, Logan L. *
- 1LT Walrath, Jacob D.

Warrant Officers

- WO1 McKnight, Matthew B. * -DG
- WO1 MacIsaac, Kelsey N. * -HG
- WO1 Marquart, Preston J. -HG
- WO1 McCormick, Anthony R. -HG
- WO1 White, Parker M. -HG
- WO1 Allaire, Chad P., Jr.
- WO1 Ballardini, Justin A. *
- WO1 Bell, Alexandria J.
- WO1 Calchera, Robert T. *
- CW2 Cardel, Andred
- WO1 Clamp, Trace A.
- WO1 Cleveland, Henry M. *
- WO1 Foster, Michael B. *
- WO1 Franklin, Michael L. *
- WO1 Garcia, Benito P. *
- WO1 Godwin, Arik C.
- WO1 Gorham, Nathaniel E.
- WO1 Hatch, Bryson F.
- WO1 Hensarling, James R.
- WO1 Huffman, Christopher A. *



FSXXI Class 23-017



FSXXI Class 23-018

- WO1 Hutton, Kyle K.
- WO1 Jamieson, Rickey W., Jr. *
- WO1 Kallenbach, Alexander D.

- WO1 King, Shaun M.
- WO1 Lusk, Logan T. *
- WO1 McClain, Shane A.

- WO1 Monroe, Dustin A. *
- WO1 Moreno, Lorenzo S.
- WO1 Peacock, Cecil L., III *

People On The Move

Flight School *Continued*

W01 Rudiak, Matanel
 W01 Stacey, Evan R.
 W01 Thompson, Brady J. *
 W01 Trujillo, Nicholas C. *
 W01 Tuss, Ryan T. *

59 Officers July 13, 2023

Class 23-018

Commissioned Officers

1LT Jett, Connor M. -HG
 1LT Smalls, Alexis J. -HG
 1LT Van Nortwick, Ryan M. * -HG
 1LT Waldman, Abigail H. * -HG
 2LT Barnes, Emanuel I., IV *
 2LT Borrajo, Jeremiah L. *
 2LT Calvert, Paul J., Jr. *
 2LT Cannon, Corey D. *

2LT Carter, Britney K. *
 1LT Covey, Kai J. * -DG
 2LT Dumas, Charles R. *
 2LT Gandy, Zachary O. *
 1LT Garrity, Kellie B. *
 1LT Headrick, Seth C.
 2LT Parks, Grady D., II
 2LT Reese, Thomas C.
 1LT Rhazaoui, Khalil *
 1LT Schlottfeldt, Kevin J.
 1LT Shim, Avery J.
 2LT Shope, Cole A.
 1LT Smith, Annika K.
 1LT Starrs, Patrick F.
 CPT Vander Laan, Rachel L. *
 1LT Woolsey, Shalynn N. *
Warrant Officers
 W01 Sanchez, Christian S. -DG
 W01 Barnett, Steven P., Jr. * -HG

W01 Montgomery, Anthony J. * -HG
 W01 Schmit, Andrew J. * -HG
 W01 Wilson, Zane A. * -HG
 W01 Andrusko, Andrew M. *
 W01 Bailey, John P. *
 W01 Bell, James H.
 W01 Blair, Trevin I. *
 W01 Bright, Jeffrey R.
 W01 Casamatta, Robert D.
 W01 Castaneda, Rainier M. *
 W01 Chandler, David F., Jr. *
 W01 Ciavarrro, Laura A. *
 W01 DeOliveira, Augusto B.
 W01 Elkins, Aaron M.
 W01 Guzman-Bonilla, Julio C.
 W01 Hallard, Joshua M. *
 W01 Ham, Darius S. *
 W01 Kubicz, Eric *
 W01 Lopez-Varela, Abigail

W01 Marx, Dylan R. *
 W01 McLachlan, Hunter J.
 W01 Merrill, Anthony S.
 W01 Mossett, Jonathan P., Jr.
 W01 Presnell, Damion M. *
 W01 Renner, Blake P.
 W01 Riegler, Seth J.
 W01 Schetrompf, Austin L. *
 W01 Sullimada, Anjan N. *
 W01 Sunwoo, Michael *
 W01 Torres, Abe A. *
 W01 Wallace, Christopher R.
 W01 Weatherholtz, Landon R.
 W01 Willis, Noah M.

-DG: Distinguished Graduate
 -HG: Honor Graduate
 * = AAAA Member

Naval Experimental Test Pilot School Graduates

AAAA congratulates the following officers graduating from the United States Naval Test Pilot School at the U.S. Naval Facility, Patuxent River, MD

05 Officers Class 162

CPT Bailey, Jaryd J.
 CPT Franchino, Vincent M.
 CPT Gallup, Matthew G.
 CW3 Reaves, Ryan W.
 CW4 Fleming, Patrick W.

ADVANCED INDIVIDUAL TRAINING (AIT) GRADUATIONS

AAAA congratulates the following Army graduates of the indicated Advanced Individual Training (AIT) courses at the 128th Aviation Brigade, Joint Base Langley-Eustis, VA and the U.S. Army Aviation Center of Excellence, Ft. Rucker, AL.

AH-64 Attack Helicopter Repairer (15R)

Class 021-23
 PV1 Jungsu Kim * -DG
 CW2 Saeed Taleb S. T. Al Menakhas
 SGT Easa Ahmed S. H. Al Naqbi
 1LT Mohamed Rashed M. S. Al Yammahi
 SPC David Brian Chavez
 PFC Suliana Jimenezvelez
 PV1 Hunter Michael Oshell
 PV1 Manuel Rafael Riverapohl
 PV2 Rashaun Jaden Skoda
 PV1 Kevin Vallejo, Jr.
 PFC Joshua Christopher Whalen

Class 022-23
 PFC Jacob Shaw Lee * -DG
 PFC Christian Banes Alcover
 PV1 Elijah Job Browning
 PFC Joshua John Fisher
 PFC Xi Jiang
 SGT Matthew Medellin
 SPC Roosevelt Jordan Pinacabreja
 SPC Gabriel D Rasmussen
 Class 023-23
 CW2 Amer Saleh F. O. Al Farroukh
 MSG Hyeunjin Kim
 PV2 William Lineberger, III
 PV2 Ethan Simmons

CH-47 Medium Helicopter Repairer (15U)

Class 017-23
 PV2 Ethan Hartmann * -DG
 MSG Hudaish Asiri
 PV2 Ariel Basulto
 PFC Julian Bona
 SPC Joshua Caldwell
 SPC Patrick Cogdill
 PV2 Erik Gaspargamagna
 SPC Yanyiu Jiao
 PV2 Hayden Lemberger
 PFC Abigail McNeil
 Class 018-23
 PV2 Cody Wayrynen * -DG
 SPC Wilfredo Estevezramos
 SPC Dalton McBride
 PFC Tyler McIntyre
 SPC Christopher Miracle, Jr.
 PV2 Remone Parker
 PFC Ronan Perloff
 PFC Landon Rith
 CPL Nathaniel Taylor

UH-60 Helicopter Repairer (15T)

Class 044-23
 PV2 Christopher J. Harrington * -DG
 SPC Alexander Isiah Arce, Jr.

PV2 Malikie Emmanuel Baser
 PV2 Chase Berkeley Davis
 PV2 Ryan Jesse Demento
 SPC George Robertcharles Fritz
 SPC James Daniel Hunter
 PV2 Kevin Calunsag Jabay
 SPC Pearce Edward Keister
 PV2 Ian Atlas Macko
 SPC Hunter Cory Smith
 Class 046-23
 PFC Benjamin S. Penttila * -DG
 PFC Christian Tyler Badgett
 PFC Cross Dayne Bates
 PV2 Lucas Aaron Dunkin
 PV2 Hannah Dean Havill
 PV2 Brayden Reece Huber
 SPC Mason Lake Khandagle
 PFC Makoa Kalama Ku Aloha Ng
 SPC Cory Mitchell Reed
 PFC William Anthony Rodriguez
 SPC Anton Aaron Roysce
 PV2 Matthew S. Southworth-Fairbairn
 Class 047-23
 PFC Larry Marcus Castorena, Jr. * -DG
 PV2 Matthew Christian Badillo
 PV2 Gonzalo Bruckmansantillan
 PFC Angel Isaiah Cooper
 PV2 Osiris Prince Harris
 SPC Phillip Lyn Hatten
 PFC Isaac Scot Havir
 PV2 Nathan Lane Henry
 PFC Vladyslav Serhiov Hrinchenko
 PV2 Angel Iseah Huerta
 PFC Juhan Lee

Aircraft Powerplant Repairer (15B)

Class 008-23
 PV2 Christopher John Kastner * -DG
 SGT Abdulrahman H M Ali Al Shamsi
 SPC Miguel Angel Gaspar Jimenez
 PVT Aaron Jason Marmon
 SPC Louieelbert Estur Ocampo

Aircraft Powertrain Repairer (15D)

Class 005-23
 PV2 Carlos Morgan JaAlexander * -DG
 PFC Brandon Alexis Acevedoramos
 SPC Christopher Robin Allerdice
 PFC Julian Edward Bastardo
 PV2 Terry Trenton Carpunky
 PV2 Ivan Correa, Jr.
 SPC Aizizi Fulati
 PV2 Nikolas Hunter Green
 PV2 Joshua Marshall Myers
 PVT Blake Lee Prado
 PFC Jose Armando Rodriguez
 PFC Jinho Sun

Aircraft Electrician (15F)

Class 007-23
 SPC Hector Manuel Baeznegron
 PV2 Nathanael Alexander Colbenston
 PVT Marcus David Deranleau
 SSG Jose Manuel Fernandes
 PVT Evan James King
 PFC Jovani Luna
 SPC Jose Enrique Negronortiz

Aircraft Structural Repairer (15G)

Class 005-23
 PV2 Akram Hussain * -DG
 PV2 Austin Michael Conner
 PVT Cesar Andres Favelabarrales
 PV2 Pablo Moises Godinez
 PV2 Jonathan James Lang
 SPC William Clintburfor McDowell
 SPC Hannah Joy Worden

Aircraft Pnedraulics Repairer (15H)

Class 006-23
 SGT Ahmed Ali Salem Ali Al Mazrouei
 PV2 Tyler Drew Deegordils
[AIT *Continued next page*](#)



People On The Move

AIT *Continued*

CPL Elissa El Khoury
SSG Gian Carlo Cancio Garcia Keegan
PV2 Alexander Meyers
SSG Melvin Lavern Talbert

Avionic Repairer (15N)

Class 006-23
PV2 Coe Francis Emens, IV * -DG
WO1 Aysar AbdAl Muhdi Falah AlAjalin
PVT Jacob Matthew Becker
PVT Ismael Junio Carretos-Sanchez
PFC Joseph Allen Moore
PV2 Zoe Noel Rexrode
PFC Cameron Myles Owens
PFC Abigail Nancy Stollsteimer
Class 007-23
PFC Joseph Anthony Scalia * -DG
PV2 Hunter Cole Coffey
PVT Joshua Mykham Gahara
PFC Austin Patrick Green
PFC David Jeffery Hays
SPC Nicolas Nathan Munoz
PFC Ethan Trinidad Sandoval
PV2 Jacob Michael Sobollik

AH-64 Armament/ Electrical/Avionic Systems Repairer (15Y)

Class 007-23
PFC Hunter Matthew Stoliker * -DG

1LT Mohamed Amine Akka
WO1 Abdulla Abdulaziz A.A. Al Derhim
WO1 Talal Abdulsalam M.A. Al Harbi
PV1 Larry Andrew Beggs, III
SSG Eamon O'Malley Fuery
PV2 Austyn Ryan Grantham
PV2 Neal Ammon Jamora
PV2 Garrett Alan Johnston
SPC Michael Scott Lacy
PV1 Keegan-Lee Mills-Horne
PV1 Octavio Torres
Class 009-23
PV2 Dinhphi Conner Tran * -DG
SPC Anthony Javier Jimenezarvelo
PV1 Henry Pecina Fernandez
PV2 Cody Lee Price
PV1 Brian Michael Quidachay
PV2 Curtis Quannathaniel Rencher
SPC Javier Antonio Romero
PV1 Todd Michael Schlegel
SSG Hector Cesar Yepes

Unmanned Aircraft Systems (UAS) Graduations UAS REPAIRER

AAAA congratulates the following Army graduates of the Shadow Unmanned Aircraft Systems Repairer Course, MOS 15E, at Fort Huachuca, AZ.

Shadow UAS Repairer

Course

3 Graduates, 29 June 2023
PFC Jonah Ayala
PFC Elijah J. Wirtes
PV2 Cameron A. Cantrell

Gray Eagle UAS Maintainer Course

5 Graduates, 21 June 2023
PV2 Kylie Chislow -DG
PVT John Grayson
PVT William Rikeman
PVT Ethan Doll
DAC Trevor Goeppinger

UAS OPERATOR

AAAA congratulates the following Army graduates of the Unmanned Aircraft Systems Operator Course, MOS 15W, at Fort Huachuca, AZ.

Shadow UAS Operator Course

4 Graduates, 30 June 2023
SPC Christian Torres Perez
PFC Ian Anglin
PFC Maisie Watson
PV2 Carter Shook
8 Graduates, 20 July 2023
PFC Charles Newfield -DG
SPC Trysten Smith

PVT Meluska Eustache
PFC Skylar Hoffert
PVT Aden Oakes
PFC Augustine Ramirez
PV2 Samuel Beck
PV2 Nolan Chamber

Gray Eagle Operators Course

5 Graduates, 19 July 2023
PFC Sofia Yousefi -DG
PVT Wesley Beason
PFC Breanna Champion
PFC Jenessa Cisneros
PFC Michael Wilkie
6 Graduates, 19 July 2023
PVT Payton Bocks -DG
PVT Kyle Fuller
PVT Ethan Ilsey
SPC German Marin
PFC Aaron Mccann
PFC Marco Rodriguez-Millan

DG - Distinguished Graduate
HG - Honor Graduate
* = AAAA Member

ARMY AVIATION ▶ Advertiser Spotlight

Blackhawk Aerospace



COMPANY DESCRIPTION – Blackhawk Aerospace Solutions (BAS), LLC provides aircraft Maintenance, Repair, & Overhaul management services, engine upgrades, composite aerospace parts, aircraft powerplant and avionics modifications, and aircraft repair services. BAS' QMS is ISO 9001 :2015 and AS 9100 Rev D certified. BAS is located in Huntsville, AL, registered in SAM, and have a DUNS number of 825124980 and a Cage Code of 5B6T4.

SIZE OF COMPANY: Small 0-99 Employees,
CATEGORIES: Maintenance & Product Overhaul, Veteran-Owned Business, Propulsion Systems

<https://www.blackhawk.aero/>

Industry News *Announcements Related to Army Aviation Matters*

Editor's note: Companies can send their Army Aviation related news releases and information to editor@quad-a.org.

Boeing Transitions to New CH-47 Chinook Production with Final Block I Contract



U.S. ARMY PHOTO

As part of a U.S. Department of Defense Foreign Military Sale (FMS), Boeing received a contract to produce 18 CH-47F Block I Chinooks for South Korea and one additional aircraft for Spain. As Boeing continues transitioning to building the advanced Block II configuration, the deal valued at up to \$793 million represents the final aircraft to be ordered on the current CH-47F Block I FMS contract with the U.S. government. Although production and deliveries of the CH-47F Block I will conclude with this order in 2027, Chinook modernization efforts will continue with the already underway H-47 Block II program.

FSI Defense Selected to Train Army Aviators



FSI DEFENSE GRAPHIC

General Dynamics Information Technology (GDIT) selected subcontractor FSI Defense, a FlightSafety International company, to deliver services and support to the U.S. Army's Aviation Center of Excellence (USAACE) at Fort Novosel, Alabama. The 12-year Flight School Training, Support, and Services (FSTSS) contract provides manufacturing, advanced simulation training, and instruction to military aviators and international partners for initial pilot qualification and advanced aircrew training.

First Flight of GA-ASI New Heavy Fuel Engine For Gray Eagle ER

General Atomics Aeronautical Systems, Inc. (GA-ASI) conducted the first flight of its new



FSI DEFENSE GRAPHIC

200-horsepower heavy fuel engine on a Gray Eagle aircraft at its El Mirage flight facility on May 9, 2023. The Heavy Fuel Engine (HFE) 2.0 is being considered by the U.S. Army to become the fleet replacement for the current 180-horsepower engine used by the Gray Eagle Extended Range (GE-ER) Unmanned Aircraft System (UAS). HFE 2.0 is also the cornerstone of the modernized Gray Eagle 25M (GE-25M) aircraft currently being developed under a U.S. Army-funded program.

Contracts – (From various sources. An “*” by a company name indicates a small business contract / “***” indicates a woman-owned small business)

Raytheon Co., McKinney, TX, was awarded a \$48,000,000, firm-fixed-price, cost-plus-fixed-fee, indefinite-delivery / indefinite-quantity contract to provide life-cycle contractor support for the AN/ZSQ-2 Forward Looking Infrared and Electro-Optical Sensor System for the U.S. Special Operations Command (USSOCOM), Technology Applications Program Office; the majority of the work will be performed at Fort Campbell, KY, and is expected to be completed by April 30, 2028.

Technical Services LLC,* Madison, AL, was awarded a \$99,886,000 cost-plus-fixed-fee contract for flight test engineering support, aviation maintenance support, prototype development, and aircraft modifications and upgrades; work locations and funding will be determined with each order, with an estimated completion date of Dec. 31, 2028.

The Boeing Co., Ridley Park, PA, was awarded two contracts: a \$793,350,000 firm-fixed-price contract for aircraft; work locations and funding will be determined with each order, with an estimated completion date of Dec. 30, 2027; and a \$22,500,000 firm-fixed-price contract for CH-47 long lead items; work locations and funding will be determined with each order, with an estimated completion date of Sept. 30, 2024.

Advertisers Index

Akima	7
Amentum	49
Army Aviation Museum Foundation	67
Astronics Test Systems	17
AVT Simulation	44
Bell	69
Breeze-Eastern	61
Coastal Seat Cushions, Inc.....	36
Crestwood Technology Group (CTG).....	41
Dallas Avionics	31
David Clark Company.....	35
Dayton-Granger, Inc.	61
Eclipse International Group	55
First Aviation.....	27
FlightSafety International	11
Freeman Holdings.....	63
Garmin International Inc.	15
GE Aerospace.....	9
Gill Aviation.....	32
Gulfstream Aerospace Corporation, a Georgia Corp.	19
Helibasket	39
Honeywell Aerospace	53
King Aerospace.....	27
L3Harris IMS Wescam.....	147
Lockheed Martin.....	1
Marvin Test Solutions, Inc.	47
MD Helicopter.....	29
MOOG Space and Defense Group	25
North Atlantic Industries, Inc.	57
PBS Aerospace Inc.....	67
PCX Aerosystems.....	43
Phantom Products, Inc.	37
Recoil Aerospace	65
Roberston Fuel Systems, LLC.....	21
Rolls-Royce.....	2
S.A.F.E. Structure Designs, LLC.....	73
Science and Engineering Services, LLC.....	144
Simulator Product Solutions (SPS).....	59
SKEDCO, Inc.....	52
Spokane Industries, Inc.....	45
StandardAero	22
Summit Aviation Inc.....	16
Technisonic	23
Textron Systems	5
True Blue Power.....	51
Tyonek	57
Vinnell Arabia.....	71
W.L. Gore & Associates	13
Yulista Holdings, LLC.....	65



AAAA Legislative Report

By LTC (Ret.) Patrick "Josh" Baker
AAAA Representative to the Military Coalition (TMC)
josh.baker@quad-a.org

Defense Bills Passed by 30 September?

On the surface it seems as if Congress desires to execute the timely passage of the Fiscal Year 2024 Defense Bills. Swift passage in the respective committees provide the illusion

that the historical onslaught of continuing resolutions will be averted. Unfortunately, this is highly unlikely. The Army Aviation budget will be held hostage in the process. In the meantime, a peek into the HAC-D markup is worth a review.

Green Program Funding Net Increase		Red-Program Funding Net Decrease	
PROCUREMENT (Proc)			
Program	Requested	HAC-D Mark	Comment
Future UAS Family	\$53,453	\$53,453	
Small UAS (SUAS)	\$20,796	\$30,769	Accelerate short range recon fielding
Apache Block 3 Reman	\$718,578	\$536,502	GFE ahead of need, cost carryover, delays
Apache Block 3A Reman (AP)	\$110,360	\$110,360	
Blackhawk M Model (MYP)	\$668,258	\$788,258	Additional National Guard aircraft
Blackhawk M Model (AP)	\$92,494	\$92,494	
Blackhawk L & V Models	\$153,196	\$153,196	
Chinook	\$202,487	\$195,329	Digital cockpit insufficient justification
Chinook (AP)	\$18,936	\$18,936	
Gray Eagle Payload	\$13,650	\$13,650	
Gray Eagle Mod2	\$14,959	\$82,959	MQ-1C 25M Capability improvement
Apache Mods	\$113,127	\$113,127	
Chinook Mods	\$20,689	\$35,689	Hybrid enhanced ballistic protection
Blackhawk Helicopter Mods	\$35,879	\$53,379	60kVA generators, powered ascenders
Network and Mission Planning	\$32,418	\$44,418	Aviation Mission Common Server
COMMS, Nav Surveillance	\$74,912	\$74,912	
Degraded Visual Environment	\$16,838	\$16,838	
Aviation Assured PNT	\$67,383	\$67,383	
GATM Rollup	\$8,924	\$8,924	
UAS MODS	\$2,258	\$2,258	
ASE	\$161,731	\$126,792	Carryover
Survivability Countermeasures	\$6,526	\$6,526	
CMWS	\$72,041	\$72,041	
CIRCM	\$261,384	\$261,384	
Common Ground Equipment	\$25,752	\$25,752	
Aircrew Integrated Systems	\$22,097	\$22,097	
Air Traffic Control	\$21,216	\$21,216	
Launcher, 2.75 Rocket	\$2,125	\$2,125	
RESEARCH DEVELOPMENT TEST & EVALUATION (RDT&E)			
Program	Requested	HAC-D Mark	Comment
Future Vertical Lift Technology	\$73,844	\$93,844	eVtol power source, composites, robotics
Air Platform Applied Research	\$48,163	\$53,163	Manufacturing tech for reverse engineering
Air Platform Advanced Tech	\$14,165	\$14,165	
Future Vertical Lift Advanced Technology	\$158,795	\$206,045	Various
Aviation Advanced Development	\$1,502,166	\$1,493,804	(-)FARA ahead of need, (+) Flight Control
Small Unmanned Aerial Vehicle (SUAV)(6.4)	\$5,144	\$5,144	
Future Tactical UAS	\$53,143	\$63,143	Battlefield Communication
Aircraft Avionics	\$13,673	\$13,673	
Air Traffic Control	\$1,134	\$11,134	Integrated mission planning
Aircraft Survivability Equipment	\$24,900	\$24,900	
Small Unmanned Aerial Vehicle (SUAV)(6.5)	\$31,284	\$24,769	LRR insufficient justification
Aviation Ground Support Equipment	\$1,167	\$1,167	
Aircraft Certification	\$2,718	\$2,718	
Blackhawk Product Improvement Program	\$1,507	\$33,514	Block 2, Main Rotor blade modernization
Chinook Product Improvement Program	\$9,265	\$14,265	Reliability, availability, maintainability
Improved Turbine Engine Program (ITEP)	\$201,247	\$176,956	Program delays
Aviation Rocket System Product Improvement	\$3,014	\$3,014	
Unmanned Aircraft Systems Universal Products	\$25,393	\$25,393	
Apache Future Development	\$10,547	\$15,547	Strap down pilotage
Aircraft Engine Component Improvement Program	\$146	\$146	
Airborne Recon Systems	\$0	\$5	Imaging cold environments
MQ-1C Gray Eagle UAS	\$6,629	\$6,629	

UPCOMING AAAA EVENTS

OCTOBER 2023

- 9-11 AUSA Annual Meeting, Washington, DC
- 16-20 U.S. Army Warrant Officers Association 51st Annual Meeting, Atlantic City, NJ
- 28 Military Officers Association of America Annual Meeting, Kansas City, MO

NOVEMBER 2023

- 13-15 AAAA Cribbins Army Aviation Readiness Symposium, Huntsville, AL
- 13 AAAA National Executive Board, Scholarship Foundation Board of Governors, TLC Foundation Board Meetings, Huntsville, AL

ARMY AVIATION

Upcoming Special Focus



OCTOBER

- Aviation Sustainment
- Aviation Support
- Aviation Soldier Support

NOVEMBER

- Unmanned Aircraft Systems
- Fixed Wing
- Air Traffic Services
- Corpus Christi Army Depot

Contact:
Bob Lachowski
Erika Burgess or
Carmen Touhy

AAAAindustry@quad-a.org
203. 268.2450
ARMYAVIATIONmagazine.com

By Mark Albertson



Art's Attic is a look back each issue at 25 and 50 years ago to see what was going on in ARMY AVIATION Magazine. Contributing editor Mark Albertson has selected a few key items from each decade's issues. Art Kesten is our founder and first publisher from 1953 to 1987. He is also the founder of the AAAA in 1957 and served as its Executive Vice President. The cartoon, right, was created back in 1953 by LT Joe Gayhart, a friend of Art's and an Army Aviator, showing the chaos of his apartment-office in New York City where it all began.



25 Years Ago

August/September 1998

"Great Aviation Leaders"

Major General Daniel J. Petrosky penned an article in the August-September 1998 issue of Army Aviation, pages 6, 8 & 10, "Great Aviation Leaders." Highlighted were: James H. Doolittle, James M. Gavin, George P. Seneff and

Harry W.O. Kinnard. Jimmy Doolittle is a standout because of his many contributions to military aviation. Among them is his enduring fame for taking off land-based B-25 medium bombers from carrier Hornet to bomb Japan, April 18, 1942. He had set world records on speed, altitude and endurance flying, acrobatic flying, blind flying and landing techniques and, helped to refine superior fuels that provided the Allies with obvious advantages in prosecuting the air war in World War II.

Briefings

Secretary of Defense, William S. Cohen, has announced the presidential nomination of Major General Daniel J. Petrosky, U.S. Army, for appointment to the grade of lieutenant general. In addition, he has been assigned as Commanding General, Eighth U.S. Army/Chief of Staff, U.N. Command/Combined Forces Korea. Since September 1996, General Petrosky has served as Commanding General, United States Army Aviation Center and Fort Rucker in Alabama.



Briefings



Chief of Staff, U.S. Army, has approved the assignment of Brigadier General Anthony R. Jones, from Assistant Division Commander (Maneuver), 1st Armored Division, U.S. Army Europe and Seventh Army, Germany, to Commanding General, U.S. Army Aviation Center and Fort Rucker, Alabama. The change of command is to take effect September 23, 1998.

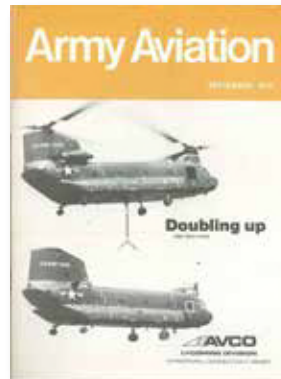

50 Years Ago

August/September 1973

Run For Your Life

A USAAVNS check pilot, CW3 Albert J. Ladesic, is a runner with a purpose. With his "Run for your Life" program, the stress is on physical conditioning. Ladesic



plans to run 2,000 miles in two years. Presently he is at five miles daily, running six days per week.

"1973 Hot Lips Houlihan Medical Mess Kit Repair Unit of the Year Award."



Actress Loretta Swit paid a visit to the Sharpe Army Depot. Ms. Swit, who portrays "Hot Lips" Houlihan on the popular television show MASH, is shown taking the pulse of Captain Harold Franklin. Ms. Swit presented the award named for her television character to the Sharpe Army Depot

for its responsibility for repairing Army medical equipment.

Longest Blade

The Boeing Vertol Company set a record last week. The company produced the largest helicopter rotor blade in the Free World. The blade is one of eight featured on the Army's XCH-62 heavy lift helicopter. The blade stretches 41 feet six inches and weighs 750 pounds.



The First



Sitting in the cockpit of an Army TH-55 at Fort Rucker, Alabama, is Barbara Elizabeth Schoen. Private Schoen is the first woman to enlist for the Army Aviation helicopter training program. With Elizabeth Schoen is Brigadier General Mildred C. Bailey, Director of the Women's Army Corps.



The Army Aviation Hall of Fame, sponsored by the Army Aviation Association of America, Inc., recognizes those individuals who have made an outstanding contribution to Army Aviation.

The actual Hall of Fame is located in the Army Aviation Museum, Fort Novosel, Ala.

The deadline for nominations for the 2025 induction is June 1, 2024

Contact the AAAA National Office for details and nomination forms at (203) 268-2450 or visit www.quad-a.org

Army Aviation Hall of Fame

Chief Warrant Officer Five Karl H. Schmidt

*Army Aviation Hall of Fame 2017 Induction,
Nashville, TN*

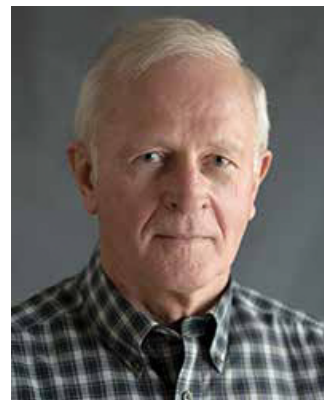

CW5 (Ret.) Karl Schmidt's forty-six years in Army Aviation with over 30 years in Special Operations Aviation is unmatched. He amassed over 15,800 hours in forty various aircraft, serving around the world including Vietnam, Korea, Germany, Central and South America, the Middle East, and other classified locations. He served 32 years as an Army Aviator, including Vietnam as a pilot, earning the Bronze Star and 16 Air Medals, and recording 840 combat hours with the Americal Division.

Following the failed "Desert One" mission, he was one of ten pilots selected to become a "plank holder" within the Special Operations Aviation forces. As an SOF Aviator, Schmidt was a troop commander, standardization instructor pilot, experimental test pilot, and lead research and development officer, placing him on the cutting edge of the development of mission equipment packages in use today.

Over his career, he flew 15,804 accident free flight hours, 3,250 night vision goggles (NVG) hours, 10,628 instructor pilot hours and earned the Federal Aviation Administration Airline Transport Pilot and Certified Flight Instructor ratings and the British equivalent of both.

He was part of advanced operations in the Grenada invasion; instrumental during the reflagging of tankers transiting the Straits of Hormuz, perfecting over-water flight under NVGs and earning an air medal while flying 280 combat flight hours. In 1981 he was awarded a Distinguished Flying Cross for a mission in direct support of a National Command Authority mission.

CW5 (Ret.) Karl Schmidt is a pioneer in Army Aviation and his contributions continue to positively impact the Department of Defense.



WESCAM MX SYSTEMS



COMBAT-PROVEN PRECISION WITH WESCAM MX™-SERIES SOLUTIONS

Control the battlefield and execute quick-strike capability with extreme precision and agility. Operate at ranges outside of the light-weapon threat envelope. L3Harris' portfolio of WESCAM MX targeting systems provides powerful designating capabilities and combat-proven solutions for day, low-light and night missions.

- > Maintain full situational awareness while identifying targets of interest with separate wide angle and spotter cameras
- > Achieve precise targeting with an independent, fully-stabilized designator
- > Keep cross-hairs on target with accurate and stable geolocation and auto-mode steering
- > Nose, pylon, canopy and mast sensor mounting options

Learn more at www.L3Harris.com/MX15D

L3HARRIS.COM

©photo Anthony PECCHI.
MD Helicopter.



L3HARRIS®
FAST. FORWARD.



SUPPORTING WARFIGHTERS WORLDWIDE

OUR COMMITMENT TO YOU:

Always providing the highest quality work, the best products, and the quickest response to our customers.



Science & Engineering
Services, LLC